



MANUFACTURER OF LIFTING, BOLTING AND TENSIONING EQUIPMENT

- HYDRAULIC CYLINDERS
- HAND PUMPS
- SYNCHRONOUS LIFTING SYSTEMS
- HPU - HYDRAULIC PUMPS
- BOLTING TOOLS
- HYDRAULIC BOLT TENSIONERS
- HYDRAULIC NUTS
- HOT BOLTING EQUIPMENT
- TESTING AND GEOTECHNICAL EQUIPMENT
- CUSTOM MADE SYSTEMS AND EQUIPMENT



INDEX

GENERAL

PAGE

02

**FLUID POWER
TECHNOLOGY**

F.P.T. Design and manufacturing

14

**CUSTOM
DESIGN**

Production of custom high pressure equipment

20

**LIFTING
EQUIPMENT**

Production of hydraulic cylinders, hand pumps, synchronous lifting systems, HPU, hydraulic pumps, valves, hoses and system's components

120

**BOLTING &
TENSIONING
TOOLS**

Production of hydraulic bolt tensioners, hydraulic nuts, hydraulic torque wrenches, hand pumps, power units, hoses and fittings

148

**TOOLS &
SYSTEMS**

Production of nut splitters, hydraulic presses, equipment for tests and geotechnics, hot bolting equipment

F.P.T. / MANUFACTURER FOR OVER 50 YEARS

MANUFACTURING PLANT



F.P.T.



MANUFACTURING PLANT

F.P.T. / THE HIGH PRESSURE EXPERTS

3 MANUFACTURING PLANTS



Relying on F.P.T. means choosing technical solutions deriving from more than 50 years of experience in the field of hydraulics. It means utilising functional and modern technology that simplifies and improves the level of your work. It means receiving personalised service that meets your specific requirements and satisfies all needs.

From 700 to 4.000 bar. For years F.P.T. supplies the international marketplace with a complete line of highpressure hydraulic tools and equipment.

F.P.T. manufactures, assembles and tests, in company-owned facilities in Italy, a wide

range of standard products, with ample warehouse availability, that make an operator's work easier and increase efficiency in various industrial sectors.

With a profound tradition in constant evolution, highly specialised engineering and design expertise focused on developing new technical solutions, absolute quality products as well as efficient technical and after-sales service and assistance, F.P.T. has become the recognised reference in high-pressure hydraulic systems personalised to meet customers' requirements.

F.P.T. / DESIGN AND PRODUCTION



**MADE IN
ITALY**

There is only one way that allows F.P.T. to meet the needs of its customers with products able to improve their work: aiming to perfection and always seeking for the maximum benefit for the customer.



**MADE IN
EUROPE**

F.P.T. follows the strategy of the highest quality: designs, produces, assembles and tests all its products at its Italian factory and guarantees excellence in all performance, from the smallest cylinder to the most complex lifting systems.

DESIGN

Possible inspection and study of feasibility at the customer's facility: search for the best solution for every need.

The highest quality achievement starts from the engineering phase, where new designs are constantly addressed to fulfil the technical needs of the markets of reference.

PRODUCTION

Possible inspection and study of feasibility at the customer's facility: search for the best solution for every need.

The highest quality achievement starts from the engineering phase, where new designs are constantly addressed to fulfil the technical needs of the markets of reference.

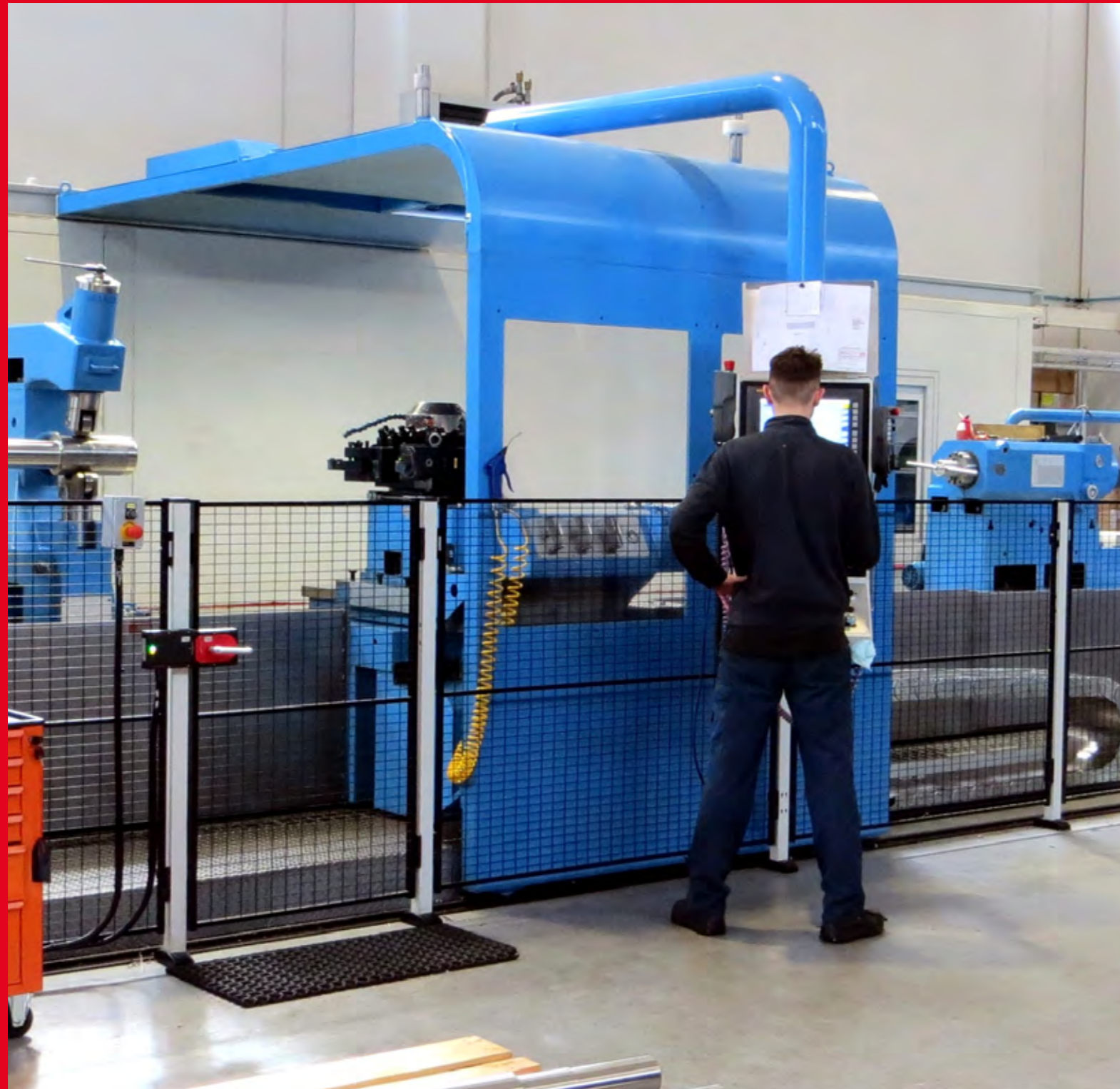

F.P.T. / PRODUCTION

FPT – Fluid Power Technology has the latest generation of CNC machine for turning and milling to manufacture all components that are assembled and tested in our facilities.

We are always ready to follow the customer in ambitious projects, producing complex components with advanced machines and technologies. Centesimal precision, boring, special manufacturing and dedicated pressure testing are our strength.

F.P.T. / ALL OVER THE WORLD

The F.P.T. products are being used everywhere in the world and in the most diversified industrial sectors. This equipment makes any lifting and handling operation of large objects, hydraulic tightening and structure's tensioning, safe and accurate.

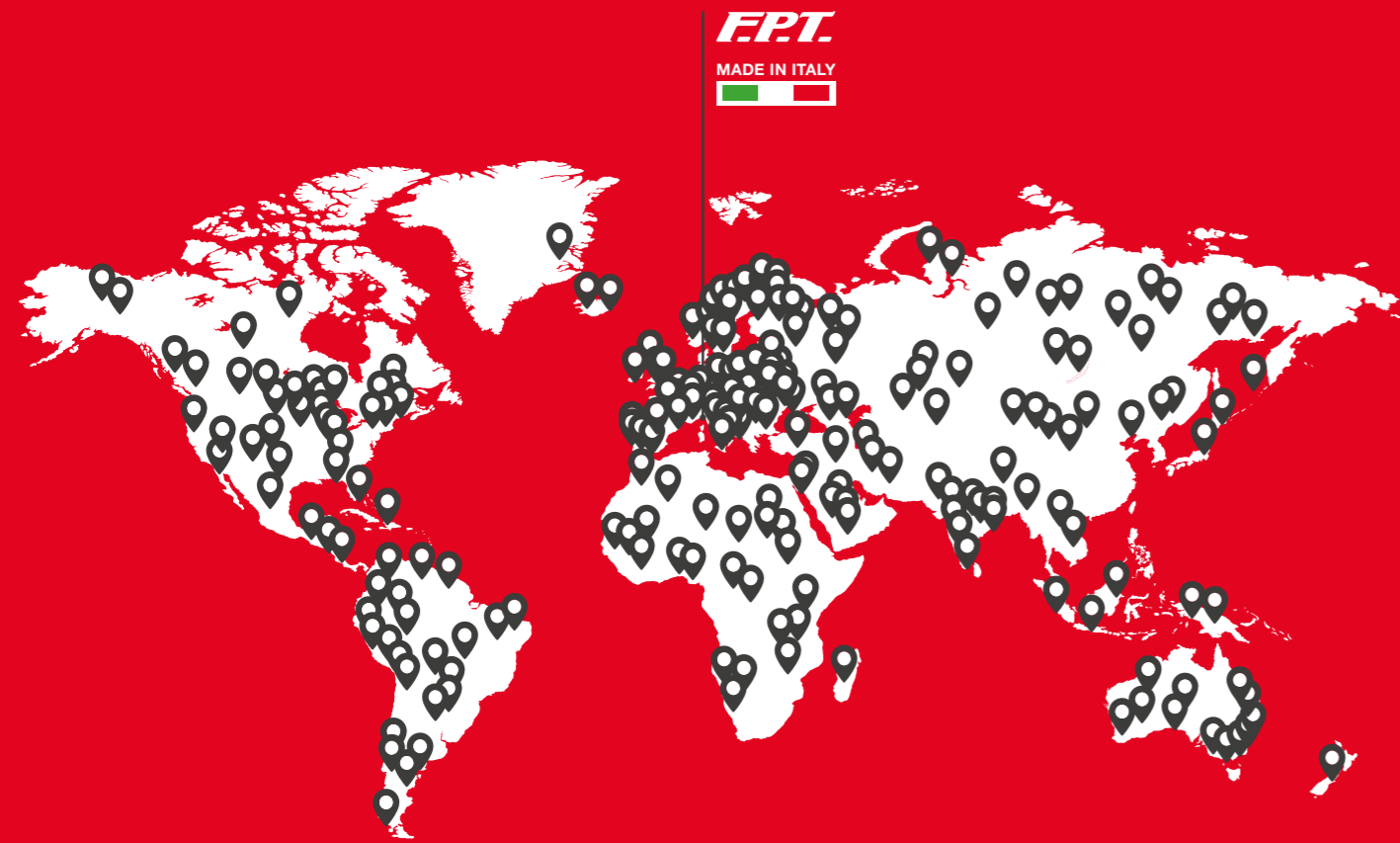

Steel

Energy

Industry

Infrastructure

Engineering & Geotechnics

Mine

Naval

Offshore

Oil & Gas

Transports



F.P.T. / AT THE SERVICE OF CUSTOMERS

EVERYWHERE IN THE WHOLE WORLD



F.P.T. / CERTIFIED QUALITY

F.P.T. features its own test department and prototype department, where constantly studies to improve production and performance take place. A metrology room is dedicated for measurement and quality control.

All our products are CE certificated, with the Quality Management System and Management of Health and Safety at Work certified ISO 9001:2015 and ISO 45001:2018.

Therefore absolutely safe and compliant to quality guidelines: especially to those that make the customer always satisfied.



CE OF CONFORMITY

F.P.T. supplies a declaration of conformity for each product and the CE mark for the products that comply with the directives of the European Community.



F.P.T. / MANUFACTURERS OF

CUSTOM EQUIPMENT

The strength of F.P.T. lies in the ability to design and implement special equipment able to respond to the most specific customer's requests. A team of specialists follow the customer during the technical consulting phase, designing, production and installation of all equipment, evaluating the best technical solutions to achieve the personalization.

01

STANDARD PRODUCTS

WHEN THE STANDARD BECOMES REFERENCE.

F.P.T. produces a wide range of standard high pressure products from 700 to 4000 bar and supplies production, technical assistance and spare parts all over the world.

02



PRODUCTS ON REQUEST

PRODUCTION Custom made hydraulic equipment

The true distinctive character of F.P.T. lies in the design and production of costum made equipment, to meet any specific customers' need: from the smaller workshop to the largest production unit, there is no industrial sector that can do without the help of our products.



PRODUCTS ON REQUEST

PRODUCTION Custom lifting equipment

Hydraulic systems created by a team of specialists and engineers, who follows the customer in the phase of technical consulting, in the analysis of the project, in the design, production and implementation of all needs, evaluating the best technical solutions in a personalized manner.



PRODUCTS ON REQUEST

PRODUCTION Custom bolt tightening equipment

F.P.T. follows the customer from the study of the geometries, to the 3D project, up to the production of the required bolt tensioners and related bolting system.

F.P.T. / LIFTING EQUIPMENT



The strength of F.P.T. lies in the ability to design and implement special equipment able to respond to the most specific customer's requests. A team of specialists follow the customer during the technical consulting phase, designing, production and installation of all equipment, evaluating the best technical solutions to achieve the personalization.

INDEX

01/
HYDRAULIC
CYLINDERS

02/
HAND PUMPS

03/
HYDRAULIC PUMPS
& SYNCHRONOUS
LIFTING SYSTEMS

04/
VALVES, HOSES
AND ACCESSORIES

LIFTING TOOLS



PAGE

22



62



76



106

F.P.T. / HYDRAULIC CYLINDERS

INDEX

HYDRAULIC CYLINDERS



01/

	Capacity ton	Stroke mm.	Series		PAGE
Spring return single acting cylinders	5-100	25-360	CRM		26
Compact, single acting cylinders with spring return	10-100	50	CRM-C		28
Extra flat, single acting cylinders with spring return	4,5-200	10-15	CRM-XP		30
Aluminium cylinders, single acting, spring return	30-100	50-150	CRMA		32
Pulling, single acting cylinders with spring return	2-100	75-160	CRM TRA CRM TR		34
Hollow, single acting cylinders with spring return	10-100	50-160	CRM-FO		36
Hollow cylinders with oil return	30-150	50-260	CRI-FO		38
High tonnage cylinders, single acting, load return	50-1000	50-300	CSE TU		40
Single acting cylinders with lock nut, low height for confined spaces	60-500	45-50	CSE GS C		44
Single acting high tonnage cylinder, load return with lock nut	50-1000	50-300	CSE GS TU		46
High tonnage cylinder, with lock nut, oil return	50-600	50-300	CRI GS TA		50
High tonnage cylinders oil return	10-500	160-330	CRI-C		54
Push-pull double acting cylinders	5-30	30-260	CDE		58

F.P.T. / HYDRAULIC CYLINDERS

Hydraulic cylinders are a very important component of the hydraulic circuit. Entirely designed and manufactured by F.P.T. in various types they can be used in different fields of application. Type of cylinder and specific applications determine different constructive methodologies.

FOR HARSH ENVIRONMENTS ANTI-CORROSIVE TREATMENT - NITOX ONC

The NITOX - ONC treatment is the modern combination of proven NITREG® technology of nitriding gas with controlled potential and a subsequent stage of oxidation followed by a sealing process using a liquid inhibitor of corrosion. It gives the surface a uniform black color that increases the resistance to corrosion and wear. Salt spray test ASTM-B117 showed corrosion resistance of over 400 hours. High resistance to corrosion, wear and fatigue.

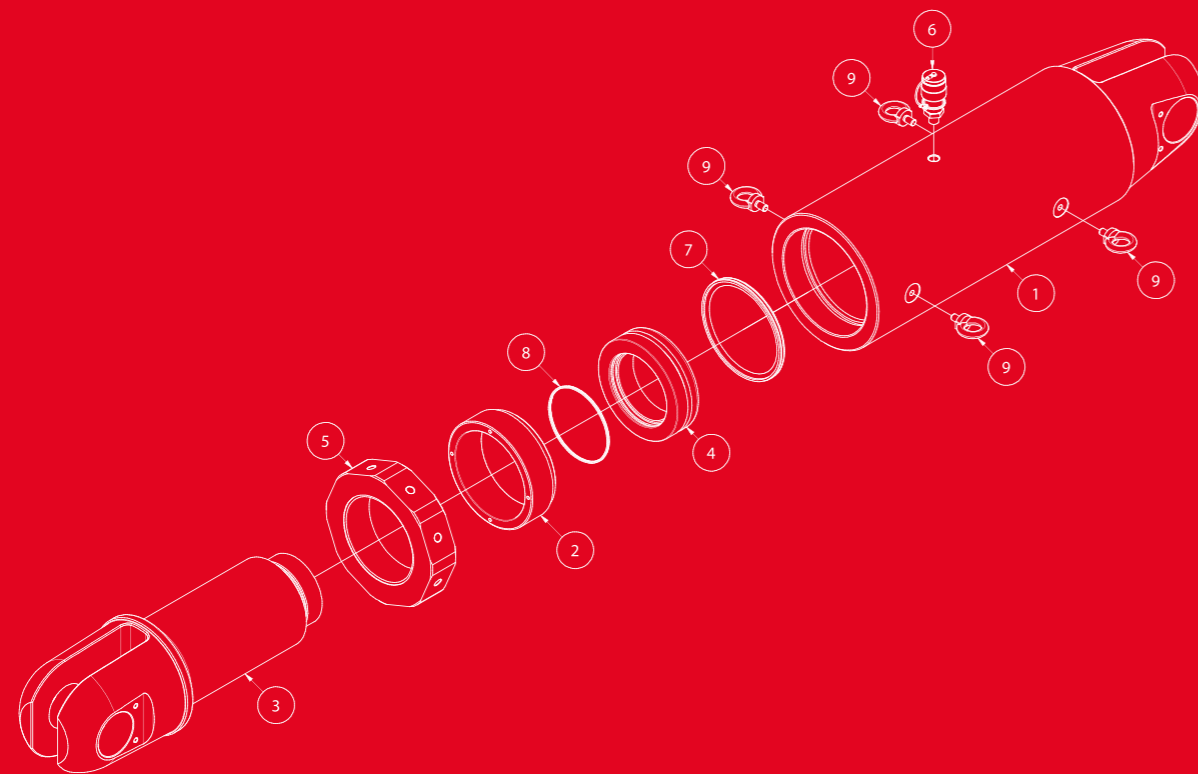

All models with a mass greater than 20 kg are equipped with lifting eyebolts.

Removable high-resistance head, possible tilting saddle for better distribution of the load to be lifted.

Exterior painting for maximum resistance to corrosion and/or Nitox ONC treatment.

Cylinders equipped with high strength seals for maximum durability over time: on request it is possible to equip the cylinder with high-strength gaskets for operative temperatures up to 200 ° C.

The guiding surfaces realized with double bronze ring are sized to guarantee optimal performance in load offset absorption and stop-ring increases safety for the operator avoiding the over stroke of the piston.

Equipped with a 3/8" NPT female coupler with dust cap.

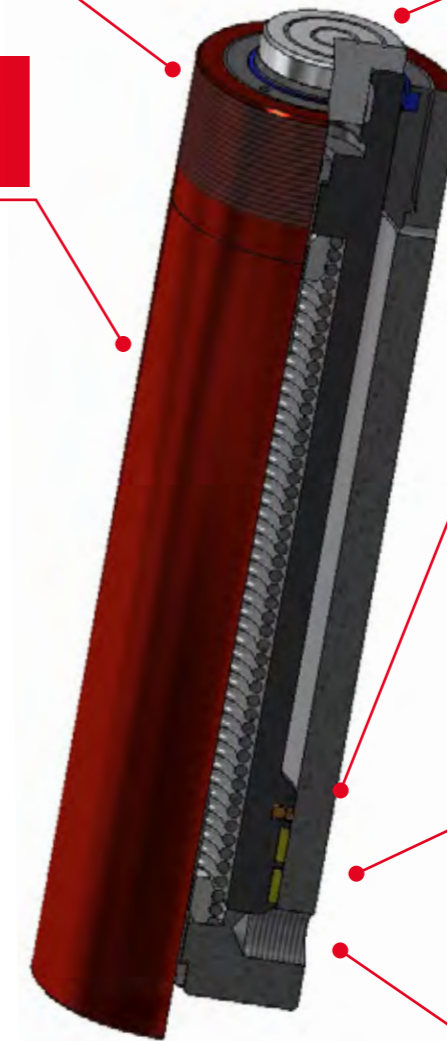

CYLINDER'S CODIFICATION DESCRIPTION

The cylinder's coding table shows the various possibilities in the product line: type of cylinder, the choice of construction materials, the piston stroke, push or pulling capacity and accessories if any.

Series	Material ↑ A – ALUMINIUM S – STAINLESS STEEL	Stroke ↑ STROKE mm	Type
CSE	A	10 100	XP TA
CSE – GRAVITY RETURN CRM – SPRING RETURN CRI-C – OIL RETURN CDE – DOUBLE ACTING		CAPACITY ↓ ton at 700 bars	GS – LOCK NUT XP – EXTRA FLAT FO – HOLLOW TRA – PULLING WITH EYELETS TR – PULLING C – COMPACT
			↑ TA – TILTING SADDLE FS – BALL JOINT



PRODUCT PAGE

The most versatile cylinder for various applications

CUSTOM CYLINDERS ON REQUEST



- Single acting cylinders with spring return, high pressure. Push force from 5 to 100 tons with range of strokes from 25 mm to 360 mm.
- Extremely versatile hydraulic cylinders, suitable for various application, for lifting, pressing and pushing.
- The guiding surfaces are sized to guarantee optimal performance in load offset absorption and stop-ring increases safety for the operator avoiding the over stroke of the piston.
- 3/8" NPT female coupler with dust cap equipped, fixing holes on the bottom surface and thread on external section of the body of the cylinder.
- Equipped with high strength gaskets for maximum durability.
- Removable high strength head and possibility of mounting a tilting saddle for better distribution of the load to be lifted.
- External painting and Nitox ONC treatment on all internal mechanical components for maximum resistance against corrosion and wear.
- All models weighing more than 20 kg are equipped with lifting eyebolts.
- Possibility to design and produce custom made hydraulic cylinders on request, with dedicated geometries, performances and features.

CRM



5-100 ton
Stroke up to 360 mm
700 bar

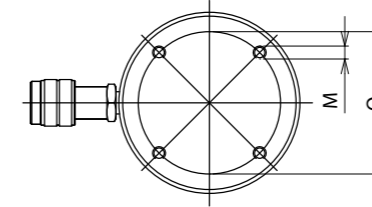

CRM

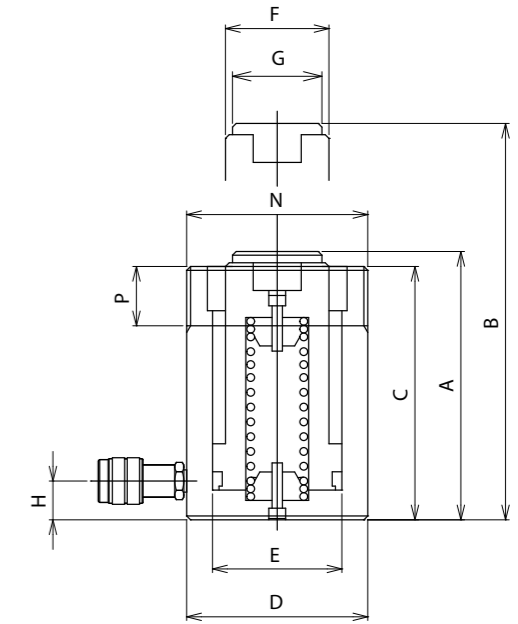

CAP/Force ton (kN)	STROKE mm	MODEL	SECTION cm ²	VOLUME cm ³	MASS kg	DIMENSIONS (mm)											
						A	B	C	D	E	F	G	H	O	M	N	P
5 /45	25	CRM-5/25	6,47	16	1,2	115	140	109	38	28,7	25	24,5	19	25	2x 1/4" - 20 UN	1 1/2" - 16 UN	28
	75	CRM-5/75	6,47	49	1,6	165	240	159	38	28,7	25	24,5	19	25	2x 1/4" - 20 UN	1 1/2" - 16 UN	28
	125	CRM-5/125	6,47	81	1,9	215	340	209	38	28,7	25	24,5	19	25	2x 1/4" - 20 UN	1 1/2" - 16 UN	28
	181	CRM-5/175SH	6,47	116	2,1	272	453	266	38	29	25	25	20	25	1/4"-20	1 1/2"-16	28
	232	CRM-5/230SH	6,47	148	2,5	324	556	318	38	28	25	25	20	25	1/4"-20	1 1/2"-16	28
10 /101	25	CRM-10/25	14,44	36	2	97	122	91	57	42,88	38	36	19	39	2x 5/16" - 18 UN	2 1/4" - 14 UN	26
	50	CRM-10/50	14,44	72	2,4	122	172	116	57	42,88	38	36	19	39	2x 5/16" - 18 UN	2 1/4" - 14 UN	26
	100	CRM-10/100	14,44	144	3,2	172	272	166	57	42,88	38	36	19	39	2x 5/16" - 18 UN	2 1/4" - 14 UN	26
	160	CRM-10/160	14,44	231	4,1	232	392	226	57	42,88	38	36	19	39	2x 5/16" - 18 UN	2 1/4" - 14 UN	26
	200	CRM-10/200	14,44	289	5,2	298	498	292	57	42,88	38	36	19	39	2x 5/16" - 18 UN	2 1/4" - 14 UN	26
	260	CRM-10/260	14,44	375	6,1	358	618	352	57	42,88	38	36	19	39	2x 5/16" - 18 UN	2 1/4" - 14 UN	26
	300	CRM-10/300SH	14,44	439	6,8	403	703	397	58	43	38	35	20	40	5/16"-18	2 1/4"-14	30
15 /137	50	CRM-15/50	19,63	98	4,4	160	210	150	70	50	40	38	20	48	2x 3/8" - 16 UN	2 3/4" - 16 UN	30
	100	CRM-15/100	19,63	196	5,5	210	310	200	70	50	40	38	20	48	2x 3/8" - 16 UN	2 3/4" - 16 UN	30
	160	CRM-15/160	19,63	314	7	270	430	260	70	50	40	38	20	48	2x 3/8" - 16 UN	2 3/4" - 16 UN	30
	254	CRM-15/260SH	19,63	515	9,1	372	626	362	70	51	41	38	25	48	3/8"-16	2 3/4"-16	30
	356	CRM-15/360SH	19,63	721	11,4	474	830	464	70	51	41	38	25	48	3/8"-16	2 3/4"-16	30
25 /232	25	CRM-25/25	33,18	83	5,5	140	165	131	85	65	55	55	20	58	2x 1/2" - 13 UN	3 5/16" - 12 UN	49
	50	CRM-25/50	33,18	166	6,3	165	215	156	85	65	55	55	20	58	2x 1/2" - 13 UN	3 5/16" - 12 UN	49
	100	CRM-25/100	33,18	332	7,9	215	315	206	85	65	55	55	20	58	2x 1/2" - 13 UN	3 5/16" - 12 UN	49
	160	CRM-25/160	33,18	531	9,8	275	435	266	85	65	55	55	20	58	2x 1/2" - 13 UN	3 5/16" - 12 UN	49
	200	CRM-25/200	33,18	664	11,1	315	515	306	85	65	55	55	20	58	2x 1/2" - 13 UN	3 5/16" - 12 UN	49
	260	CRM-25/260	33,18	863	13	375	635	366	85	65	55	55	20	58	2x 1/2" - 13 UN	3 5/16" - 12 UN	49
	300	CRM-25/300	33,18	995	14,2	415	715	406	85	65	55	55	20	58	2x 1/2" - 13 UN	3 5/16" - 12 UN	49
	362	CRM-25/360SH	33,18	1203	17,4	476	838	467	85	65	57	50	25	59	1/2"-13	3 5/16"-12	49
30 /309	210	CRM-30/210	44,18	928	19	384	594	375	102	75	60	55	46	-	-	3 5/16" - 12 UN	49
	50	CRM-50/50	70,88	354	16	180	230	175	127	95	80	72	27	95	2x 1/2" - 13 UN	5" - 12 UN	55
50 /496	100	CRM-50/100	70,88	709	20	230	330	225	127	95	80	72	27	95	2x 1/2" - 13 UN	5" - 12 UN	55
	160	CRM-50/160	70,88	1134	24	290	450	285	127	95	80	72	27	95	2x 1/2" - 13 UN	5" - 12 UN	55
	337	CRM-50/330SH	70,88	2388	39,5	461	798	456	127	95	80	70	31	95	1/2"-13	5"-12	55
100 /929	100	CRM-100/100	132,73	1327	46	280	380	275	175	130	105	92	40	140	4x 3/4" - 10 UNC	6 7/8" - 12 UN	44
	170	CRM-100/170	132,73	2256	55	350	520	345	175	130	105	92	40	140	4x 3/4" - 10 UNC	6 7/8" - 12 UN	44
	260	CRM-100/260	132,73	3451	67	440	700	435	175	130	105	92	40	140	4x 3/4" - 10 UNC	6 7/8" - 12 UN	44

Different strokes and tonnages available.



PRODUCT PAGE

When being compact is a must

CUSTOM CYLINDERS ON REQUEST



- Hydraulic cylinder, spring return, high pressure. Push force from 10 to 100 ton, stroke 50 mm.
- Lightweight, easy-to-handle cylinders with limited closed height.
- The guiding surfaces are sized to guarantee optimal performance in load offset absorption and stop-ring increases safety for the operator avoiding the over stroke of the piston.
- Equipped with high strength gaskets for maximum durability.
- 3/8" NPT female coupler with dust cap equipped.
- Non removable, high strength saddle, piston embedded.
- Nitox ONC treatment on all mechanical components for maximum resistance against corrosion and wear.
- Possibility to design and produce custom made hydraulic cylinders on request, with dedicated geometries, performances and features.

CRM-C

10-100 ton
Stroke 50 mm
700 bar

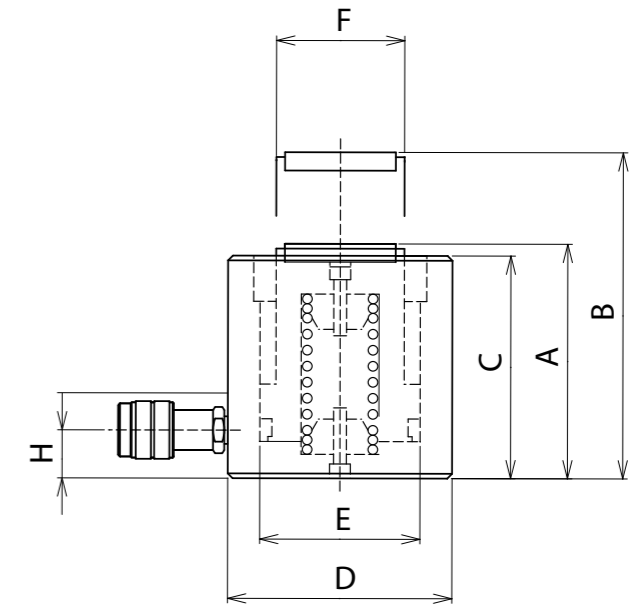

CRM-C

CAP/Force ton (kN)	STROKE mm	MODEL	SECTION cm ²	VOLUME cm ³	MASS kg	DIMENSIONS (mm)						
						A	B	C	D	E	F	H
10 /111,3	50	CRM-10/50-C	15,9	79,5	3,2	95	145	94	77	45	35	18
20 /218,2	50	CRM-20/50-C	31,2	155,9	4,7	103	153	102	93	63	50	19
30 /309,3	50	CRM-30/50-C	44,2	220,9	6,9	110	160	108	108	75	60	21
50 /549,8	50	CRM-50/50-C	78,5	392,7	9,7	120	170	118	126	100	80	19
100 /929,1	50	CRM-100/50-C	132,7	663,5	18,8	134	184	132	167	130	110	23

Different strokes and tonnages available.



Series **CRM-XP**

Extra flat, single acting cylinders with spring return



PRODUCT PAGE

Ideal for narrow and confined areas

CUSTOM CYLINDERS ON REQUEST



- Extra flat hydraulic cylinders, single acting, spring return, high pressure. Push force from 4,5 to 150 ton, range of strokes from 6 to 15 mm.
- Flat cylinders with extremely reduced closed height, ideal for working in narrow spaces where it would be impossible to use other cylinders.
- The guiding surfaces are sized to guarantee optimal performance in load offset absorption and stop ring increases safety for the operator avoiding the over stroke of the piston.
- Equipped with high-strength gaskets for maximum durability.
- 3/8" NPT female coupler with dust cap equipped.
- Non removable, high strength saddle, piston embedded.
- Nitox ONC treatment on all mechanical components for maximum resistance against corrosion and wear.
- Possibility to design and produce custom made hydraulic cylinders on request, with dedicated geometries, performances and features.

CRM-XP

4,5-150 ton
Stroke 10-15 mm
700 bar

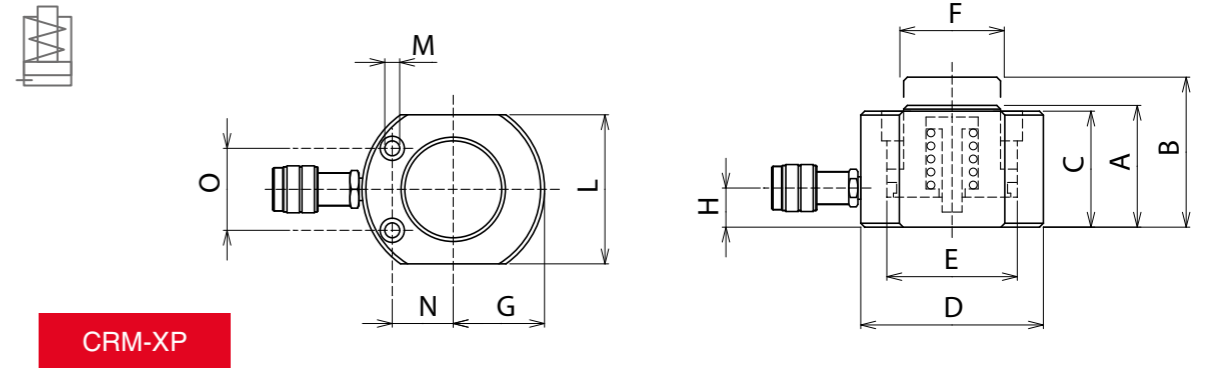

CAP/Force ton (kN)	STROKE mm	MODEL	SECTION cm ²	VOLUME cm ³	MASS kg	DIMENSIONS (mm)											
						A	B	C	D	E	F	O	H	M	N	G	L
4,5 /43,1	6	CRM-5/6-XP	6,2	3,6	1	37	43	36	59	28	24	30	18	5,5	23	23,5	45
4,5 /43,1	15	CRM-5/15-XP	6,2	9,2	1,2	46	61	45	59	28	24	30	18	5,5	23	23,5	45
10 /111,3	10	CRM-10/10-XP	15,9	15,9	1,6	50	60	49	75	45	38	40	19	6,5	28	31,5	60
20 /218,2	10	CRM-20/10-XP	31,2	31,2	3	53	63	52	101	63	50	50	19	11	40	43	86
30 /309,3	10	CRM-30/10-XP	44,2	44,2	4,2	58	68	56	117	75	60	60	20	11	45	51	102
50 /549,8	10	CRM-50/10-XP	78,5	78,5	7,4	64	74	62	147	100	80	70	22	13	58	66	130
75 /791,7	10	CRM-75/10-XP	113,1	113,1	12	70	80	68	177	120	100	90	24	13	68	81	164
100 /1077,6	10	CRM-100/10-XP	153,9	153,9	15,4	77	87	75	192	140	120	90	21	13	76	88,5	178
150 /1496,8	14	CRM-150/14-XP	213,8	299,4	29	104	118	102	227	165	130	130	25	13	80	106	215

Different strokes and tonnages available.



Series **CSE TU**

Super extra flat cylinders, very high pressure – 2.000 bar

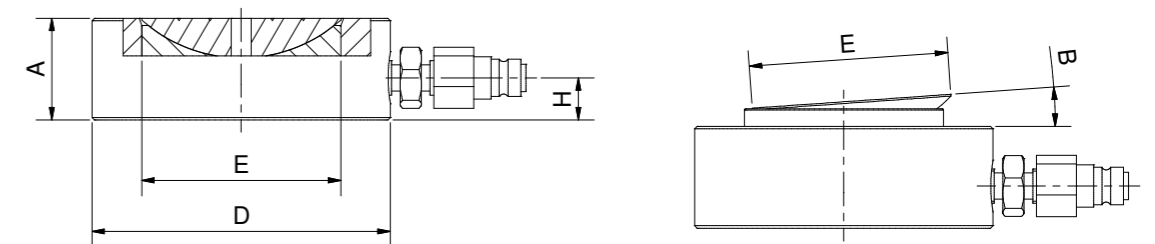

CAP/Force ton (kN)	STROKE mm	MODEL	SECTION cm ²	VOLUME cm ³	MASS kg	DIMENSIONS (mm)				
						A	B	D	E	H
100 /1005	10	CSE-100/10-TU	50,3	50	3,6	41	4°	120	80	19
200 /2077	10	CSE-200/10-TU	103,9	104	9,5	50	/	175	115	22

Super extra flat hydraulic cylinders, load return, push force from 100 to 200 tons at 2.000 bar. Used when available height is really minimal, they are suitable for working in such small spaces where it would not be possible to use the CRM XP cylinders.



PRODUCT PAGE



Light weight easy to carry

CUSTOM CYLINDERS ON REQUEST



- Hydraulic cylinders, aluminium weight, single acting spring return, high pressure- Push force from 30 to 100 ton with range of strokes from 50 to 100 mm.
- Hydraulic cylinders made of high strength special aluminum alloy, light weight, easy to carry and very easy to handle. Used in applications in which reduced weight is an important factor.
- The guiding surfaces are sized to guarantee optimal performance in load offset absorption and stop-ring increases safety for the operator avoiding the over stroke of the piston.
- Equipped with high strength gaskets for maximum durability.
- 3/8" NPT female coupler with dust cap equipped.
- High strength saddle and possibility of mounting a tilting saddle for better distribution of the load to be lifted.
- The aluminum cylinders are different from those in steel and while offering advantages in terms of weight have a different behavior at fatigue. Hence the aluminum cylinder must not be used in intensive applications.
- All models feature carry handles.
- Possibility to design and produce custom made hydraulic cylinders on request, with dedicated geometries, performances and features.

CRMA



30-100 ton
Stroke 50-150 mm
700 bar

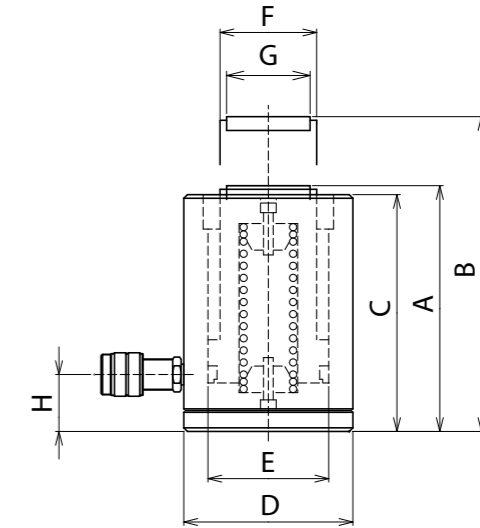

CRMA

CAP/Force ton (kN)	STROKE mm	MODEL	SECTION cm ²	VOLUME cm ³	MASS kg	DIMENSIONS (mm)							
						A	B	C	D	E	F	G	H
30 / 303	50	CRMA-30/50-SH	44,2	221	4,7	181	231	177	100	75	60	40	34
	100	CRMA-30/100-SH				231	331	227					
50 / 487	50	CRMA-50/50-SH	70,9	354	7,6	186	236	182	130	95	80	70	30
	100	CRMA-50/100-SH				236	336	232					
100 / 911	51	CRMA-100/50-SH	132,7	665	16,3	221	272	217	180	130	110	70	46
	102	CRMA-100/100-SH				271	373	267					
	152	CRMA-100/150-SH				321	473	317					

Different strokes and tonnages available.

Different models of aluminium cylinders available

- CSEA series, single acting cylinders, load return
- CSEAGS series, single acting cylinders, load return, with lock nut
- CRIA series, double acting cylinders, oil return
- CRMAFO series, single acting cylinders



PRODUCT PAGE

Pulling force: for structure approach operations

CUSTOM CYLINDERS ON REQUEST



- Single acting, pulling hydraulic cylinders with spring return, high pressure. Pushing force from 2 to 100 tons with range of strokes from 75 mm to 160 mm.
- Cylinders that operate under a pulling force. Ideal for load approach and welding operations in the shipbuilding and heavy structural steelwork sectors.
- The guiding surfaces are sized to guarantee optimal performance in load offset absorption and stop-ring increases safety for the operator avoiding the over stroke of the piston.
- Equipped with high strength gaskets for maximum durability.
- 3/8" NPT female coupler with dust cap equipped. CRM TR cylinders feature a threaded section on the body and piston to fit its accessories: chains, heads and extensions.
- External painting for maximum corrosion resistance or Nitox ONC treatment on all components for the maximum resistance to corrosion and wear.
- All models weighing more than 20 kg are equipped with lifting eyebolts.
- Possibility to design and produce custom made hydraulic cylinders on request, with dedicated geometries, performances and features.

CRM TRA-TR

2-60 ton
Stroke 127-155 mm
700 bar



CRM-TRA

CRM-TR

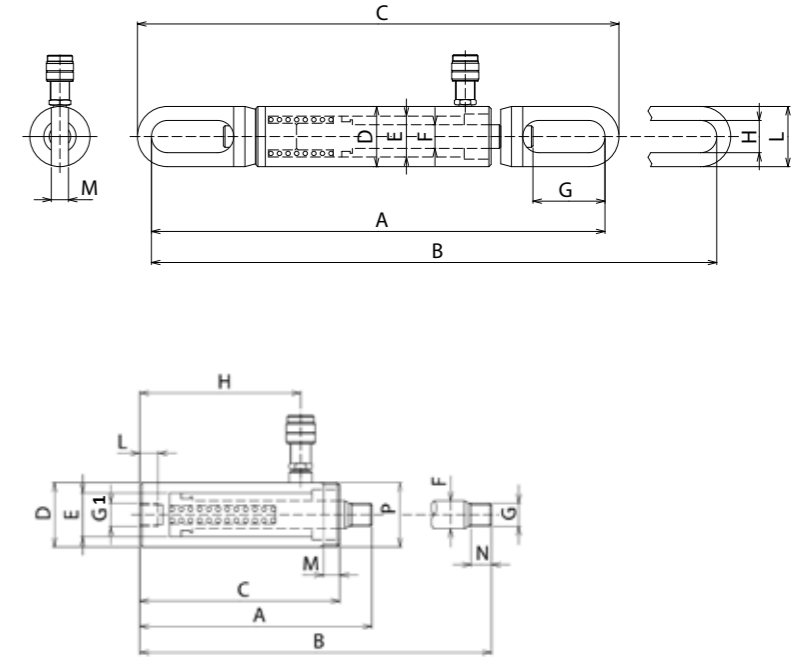

CAP/Force	STROKE	MODEL	SECTION	VOLUME	MASS	DIMENSIONS (mm)									
ton (kN)	mm		cm ²	cm ³	kg	A	B	C	D	E	F	G	H	L	
10 /109	150	CRM-10/150-TRA	15,7	235	14,5	606	756	642	78	55	32	95	42	78	
30 /304,3	155	CRM-30/155-TRA	40,84	648,5	38	810 - 914	965 - 1069	860 - 964	114	85	45	100	54	104	
60 /613,1	155	CRM-60/155-TRA	84,23	1306	92,5	840	995	918	175	125	70	137	62	140	

CAP/Force	STROKE	MODEL	SECTION	VOLUME	MASS	DIMENSIONS (mm)												
ton (kN)	mm		cm ²	cm ³	kg	A	B	C	D	E	F	G	G1	H	L	M	N	P
2 /25	127	CRM-2/127-TR-B-SH	3,6	46	2,9	268	395	236	48	29	19	M16x1,5	3/4" NPT	194	18	25	18	1/2"-16
5 /51	141	CRM-5/140-TR-SH	7,4	104	4,2	303	444	258	57	43	30	M28x1,5	1 1/4" NPT	220	24	25	22	2 1/4"-14
10 /108	151	CRM-10/150-TR-SH	15,7	236	9,5	299	450	259	85	55	32	M30x2	M30x2	221	25	25	25	M85x2

Different strokes and tonnages available.

- The eyelet can be used to adjust the extended and closed heights of the CRM30/75 TRA and CRM 30/155 TRA models.
- Construction on request of forks and pins, protective bellows and connectors or threads based on customer specifications.





PRODUCT PAGE

Cylinders for tensioning operations, maintenance and testing

CUSTOM CYLINDERS ON REQUEST



- Single acting hollow hydraulic cylinders with spring return, high pressure. Push force from 10 to 100 tons with range of strokes from 50 mm to 160 mm.
- Hydraulic cylinders with hollow center suitable for operations of tensioning, maintenance and testing; for cable tensioning operations, positioning bars in tensile structures, pulley assembly and disassembly, and cable and tie rod pulling tests.
- The guiding surfaces are sized to guarantee optimal performance in load offset absorption and stop-ring increases safety for the operator avoiding the over stroke of the piston.
- Equipped with high strength gaskets for maximum durability.
- 3/8" NPT female coupler with dust cap equipped and threaded section on the outer body of the cylinder.
- High strength head.
- External painting and Nitox ONC treatment on all mechanical components for maximum resistance against corrosion and wear up to 30 ton models. 60 ton and higher capacity models feature a Nitox ONC treatment on all mechanical parts.
- All models weighing more than 20 kg are equipped with lifting eyebolts.
- Possibility to design and produce custom made hydraulic cylinders on request, with dedicated geometries, performances and features.

CRM-FO

10-100 ton
Stroke 50-160 mm
700 bar

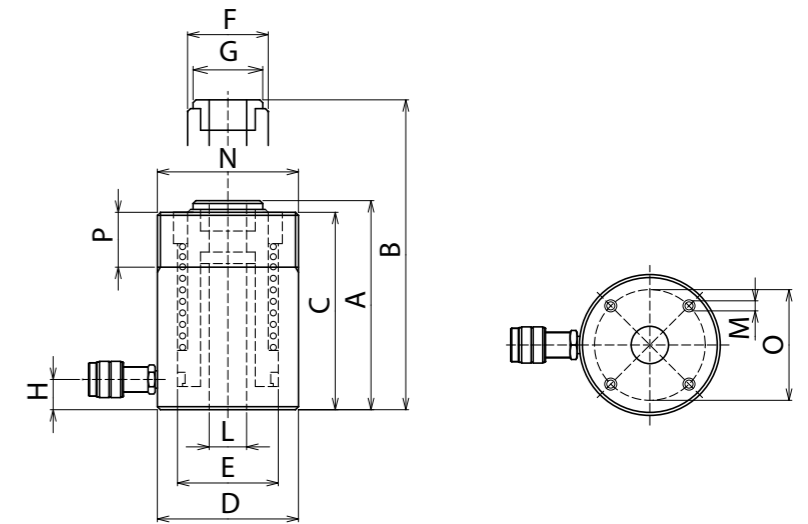

CRM-FO

CAP/Force ton (kN)	STROKE mm	MODEL	SECTION cm ²	VOLUME cm ³	MASS kg	DIMENSIONS (mm)												
						A	B	C	D	E	F	G	H	L	M	N	O	P
10 /116,8	50	CRM-10/50-FO	16,69	83	3,9	143	193	139	75	55	38	34,5	19	19,5	2xM8	M75x2	58	20
	80	CRM-10/80-FO	16,69	134	5	191	271	187	75	55	38	34,5	19	19,5	2xM8	M75x2	58	20
20 /229,9	50	CRM-20/50-FO	32,8	164	7,7	158	208	153	100	75	55	44,5	19	27,3	2xM8	M100x2	75	20
	100	CRM-20/100-FO	32,8	328	11,8	246	346	241	100	75	55	44,5	19	27,3	2xM8	M100x2	75	20
30 /300	50	CRM-30/50-FO	42,9	214	11,4	175	225	170	115	85	65	62	20	33,5	2xM10	M115x2	90	20
	100	CRM-30/100-FO	42,9	429	16,7	265	365	260	115	85	65	62	20	33,5	2xM10	M115x2	90	20
60 /589,6	50	CRM-60/50-FO	42,9	643	22,2	361	511	356	115	85	65	62	20	33,5	2xM10	M115x2	90	20
	100	CRM-60/100-FO	84,2	1264	37	337	487	325	160	125	90	90	30	54,5	2xM12	M160x4	130	35
100 /947	50	CRM-100/50-FO	84,2	1264	37	337	487	325	160	125	90	90	30	54,5	2xM12	M160x4	130	35
	75	CRM-100/75-FO	135,3	1015	55	267	342	255	215	165	125	125	38	80,5	4xM12	M215x4	175	45

Different strokes and tonnages available.

**BRIDGES - SPACERS
CUSTOM REACTION TOOLS**

Possibility of creating reaction bridges, custom spacers and specific equipment suitable for the installation on hollow cylinders.





PRODUCT PAGE

Cylinders for tensioning operations, maintenance and testing

CUSTOM CYLINDERS ON REQUEST

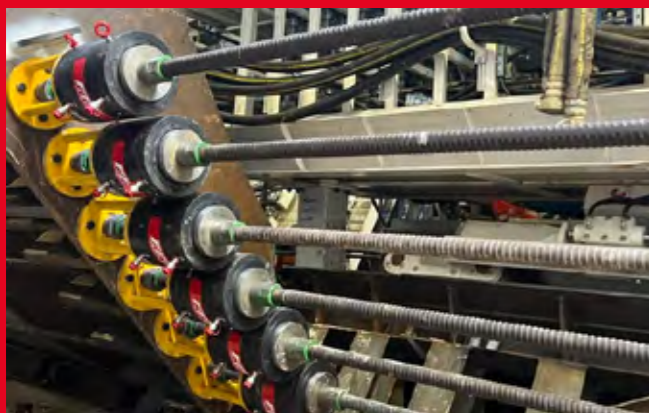

- Oil return hollow hydraulic cylinders, spring return, high pressure. Push force from 30 to 150 tons with range of strokes from 50 mm to 260 mm.
- Hydraulic cylinders with hollow center suitable for operations of tensioning, maintenance and testing; for cable tensioning operations, positioning bars in tensile structures, pulley assembly and disassembly, and cable and tie rod pulling tests.
- The guiding surfaces are sized to guarantee optimal performance in load offset absorption and stop-ring increases safety for the operator avoiding the over stroke of the piston.
- Equipped with high strength gaskets for maximum durability.
- 3/8" NPT female coupler with dust cap equipped and threaded section on the outer body of the cylinder.
- High strength head.
- External painting and Nitox ONC treatment on all internal mechanical components for maximum resistance against corrosion and wear up to 30 ton models. 60 ton and higher capacity models feature a Nitox ONC treatment on all mechanical parts.
- All models weighing more than 20 kg are equipped with lifting eyebolts.
- Possibility to design and produce custom made hydraulic cylinders on request, with dedicated geometries, performances and features.

CRI-FO

30-150 ton
Stroke 50-260 mm
700 bar

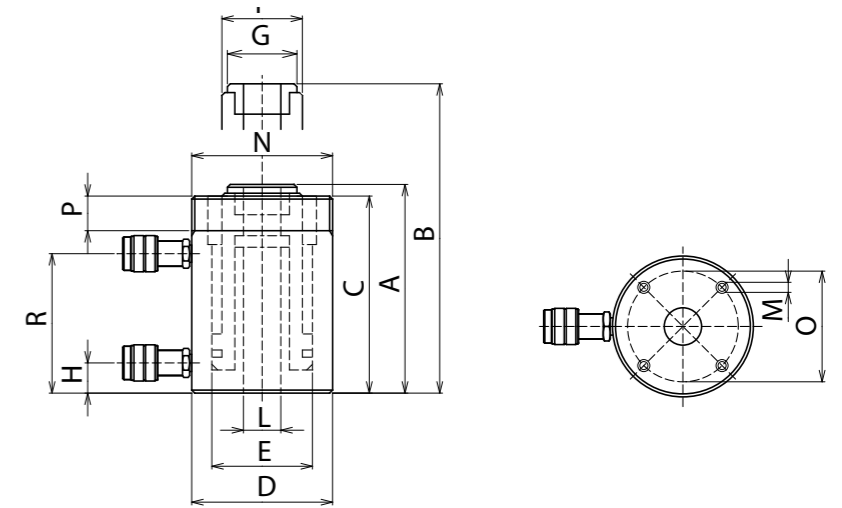

CRI-FO

CAP ton	STROKE mm	MODEL	FORCE max kN		SECTION cm ²		VOLUME cm ³		MASS kg	DIMENSIONS (mm)													
			Push	Pull	Push	Pull	Push	Pull		A	B	C	D	E	F	G	H	L	M	N	O	P	R
30	150	CRI-30/150-FO	300,2	27,5	42,9	18,3	643	274	19	302	452	296	115	85	70	62	27	33,5	2xM10	M115x2	90	20	235
	260	CRI-30/260-FO	300,2	27,5	42,9	18,3	1115	475	25,6	412	672	406	115	85	70	62	27	33,5	2xM10	M115x2	90	20	345
60	75	CRI-60/75-FO	589,6	77,8	84,2	51,8	632	389	25,1	207	282	200	160	125	95	90	30	54,5	2xM12	M160x4	130	35	143
	160	CRI-60/160-FO	589,6	77,8	84,2	51,8	1348	830	33,4	292	452	285	160	125	95	90	30	54,5	2xM12	M160x4	130	35	228
100	260	CRI-60/260-FO	589,6	77,8	84,2	51,8	2191	1348	43,3	392	652	385	160	125	95	90	30	54,5	2xM12	M160x4	130	35	328
	75	CRI-100/75-FO	947	121,6	135,28	81,09	1015	608	52	242	317	235	215	165	130	125	38	80,5	4xM12	M215x4	175	45	164
150	150	CRI-100/150-FO	947	121,6	135,28	81,09	2029	1216	65,5	317	467	310	215	165	130	125	38	80,5	4xM12	M215x4	175	45	239
	260	CRI-100/260-FO	947	121,6	135,28	81,09	3517	2108	85,4	427	687	420	215	165	130	125	38	80,5	4xM12	M215x4	175	45	349
150	200	CRI-150/200-FO	1435	160,2	205	106,8	4100	2136	101	354	554	350	247	190	139	38	80,5	-	-	-	-	-	287

Different strokes and tonnages available.

**BRIDGES - SPACERS
CUSTOM REACTION TOOLS**

Possibility of creating reaction bridges, custom spacers and specific equipment suitable for the installation on double acting hollow cylinders.



Series **CSE TU** | High tonnage cylinders, single acting, load return



PRODUCT PAGE

High tonnage

CUSTOM CYLINDERS ON REQUEST



- Single-acting high tonnage hydraulic cylinders with load return. Push force from 50 to 1000 tons with range of strokes from 50 mm to 300 mm.
- Plunger execution, equipped with stroke indicator and anti overstroke device.
- Hydraulic cylinders suitable for heavy duty applications, pushing and large lifting operations.
- The guiding surfaces are sized to guarantee optimal performance in load offset absorption.
- Equipped with high strength gaskets for maximum durability, 3/8" NPT female coupler with dust cap equipped.
- Removable high strength saddle and possibility of mounting a tilting saddle for better distribution of the load to be lifted.
- Nitox ONC treatment on all mechanical components for maximum resistance against corrosion and wear.
- All models are equipped with lifting eyebolts.
- Possibility to design and produce custom made hydraulic cylinders on request, with dedicated geometries, performances and features.

CSE TU

50-1000 ton
Stroke 50-300 mm
700 bar

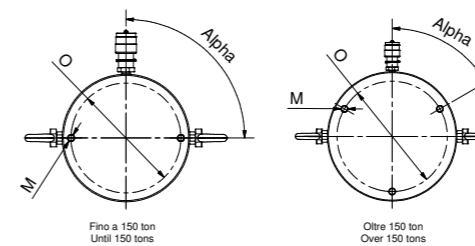

CSE TU

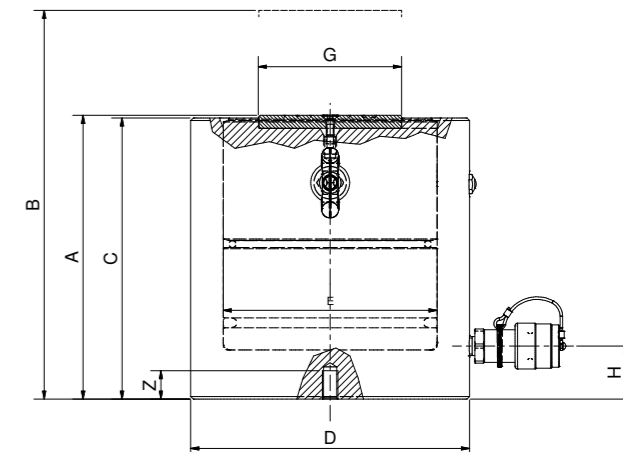

CAP/Force ton (kN)	STROKE mm	MODEL	SECTION cm ²	VOLUME cm ³	MASS kg	DIMENSIONS (mm)										
						A	B	C	D	E	G	H	M	O	Z	Alpha
50 /549,78	50	CSE50/50-TU	78,5	392,7	14,3	139	189	137	130	100	72	24	M8x1,25	105	10	90
	100	CSE50/100-TU	78,5	785,4	19,3	189	289	187	130	100	72	24	M8x1,25	105	10	90
	150	CSE50/150-TU	78,5	1178,1	24,8	239	389	237	130	100	72	24	M8x1,25	105	10	90
	200	CSE50/200-TU	78,5	1570,8	29,8	289	489	287	130	100	72	24	M8x1,25	105	10	90
	250	CSE50/250-TU	78,5	1963,5	35,3	339	589	337	130	100	72	24	M8x1,25	105	10	90
100 /1001,97	300	CSE50/300-TU	78,5	2356,2	40,3	389	689	387	130	100	72	24	M8x1,25	105	10	90
	50	CSE100/50-TU	143,1	715,7	29	154	204	152	175	135	92	33	M12x1,75	150	22	90
	100	CSE100/100-TU	143,1	1431,4	38,5	204	304	202	175	135	92	33	M12x1,75	150	22	90
	150	CSE100/150-TU	143,1	2147,1	47,7	254	404	252	175	135	92	33	M12x1,75	150	22	90
	200	CSE100/200-TU	143,1	2862,8	57,3	304	504	302	175	135	92	33	M12x1,75	150	22	90
150 /1496,77	250	CSE100/250-TU	143,1	3578,5	66,9	354	604	352	175	135	92	33	M12x1,75	150	22	90
	300	CSE100/300-TU	143,1	4294,2	76,4	404	704	402	175	135	92	33	M12x1,75	150	22	90
	50	CSE150/50-TU	213,8	1069,1	48	169	219	167	215	165	110	41	M12x1,75	185	22	90
	100	CSE150/100-TU	213,8	2138,2	62,1	219	319	217	215	165	110	41	M12x1,75	185	22	90
	150	CSE150/150-TU	213,8	3207,4	76,3	269	419	267	215	165	110	41	M12x1,75	185	22	90
200 /1984,70	200	CSE150/200-TU	213,8	4276,5	90,9	319	519	317	215	165	110	41	M12x1,75	185	22	90
	250	CSE150/250-TU	213,8	5345,6	105	369	619	367	215	165	110	41	M12x1,75	185	22	90
	300	CSE150/300-TU	213,8	6414,7	119,6	419	719	417	215	165	110	41	M12x1,75	185	22	90
	50	CSE200/50-TU	283,5	1417,6	68,5	193	243	191	250	190	138	47	M12x1,75	215	22	60
	100	CSE200/100-TU	283,5	2835,3	88,2	243	343	241	250	190	138	47	M12x1,75	215	22	60
250 /2541,35	150	CSE200/150-TU	283,5	4252,9	107,3	293	443	291	250	190	138	47	M12x1,75	215	22	60
	200	CSE200/200-TU	283,5	5670,6	127	343	543	341	250	190	138	47	M12x1,75	215	22	60
	250	CSE200/250-TU	283,5	7088,2	146,2	393	643	391	250	190	138	47	M12x1,75	215	22	60
	300	CSE200/300-TU	283,5	8505,9	165,8	443	743	441	250	190	138	47	M12x1,75	215	22	60
	50	CSE250/50-TU	363,0	1815,3	94,5	197	247	195	280	215	148	53	M12x1,75	245	22	60
250 /2541,35	100	CSE250/100-TU	363,0	3630,5	119,2	247	347	245	280	215	148	53	M12x1,75	245	22	60
	150	CSE250/150-TU	363,0	5445,8	143,4	297	447	295	280	215	148	53	M12x1,75	245	22	60
	200	CSE250/200-TU	363,0	7261,0	167,6	347	547	345	280	215	148	53	M12x1,75	245	22	60
	250	CSE250/250-TU	363,0	9076,3	192,2	397	647	395	280	215	148	53	M12x1,75	245	22	60
	300	CSE250/300-TU	363,0	10891,5	216,4	447	747	445	280	215	148	53	M12x1,75	245	22	60

CAP/Force ton (kN)	STROKE mm	MODEL	SECTION cm ²	VOLUME cm ³	MASS kg	DIMENSIONS (mm)										
						A	B	C	D	E	G	H	M	O	Z	Alpha
300 /3036,15	50	CSE300/50-TU	433,7	2168,7	126,8	222	272	220	305	235	158	58	M16x2	260	25	60
	100	CSE300/100-TU	433,7	4337,4	155,6	272	372	270	305	235	158	58	M16x2	260	25	60
	150	CSE300/150-TU	433,7	6506,0	184,3	322	472	320	305	235	158	58	M16x2	260	25	60
	200	CSE300/200-TU	433,7	8674,7	213,1	372	572	370	305	235	158	58	M16x2	260	25	60
	250	CSE300/250-TU	433,7	10843,4	242,3	422	672	420	305	235	158	58	M16x2	260	25	60
	300	CSE300/300-TU	433,7	13012,1	271,1	472	772	470	305	235	158	58	M16x2	260	25	60
400 /4007,89	50	CSE400/50-TU	572,6	2862,8	188,3	252	302	247	350	270	196	67	M16x2	300	25	60
	100	CSE400/100-TU	572,6	5725,6	226,2	302	402	297	350	270	196	67	M16x2	300	25	60
	150	CSE400/150-TU	572,6	8588,3	264,1	352	502	347	350	270	196	67	M16x2	300	25	60
	200	CSE400/200-TU	572,6	11451,1	302,5	402	602	397	350	270	196	67	M16x2	300	25	60
	250	CSE400/250-TU	572,6	14313,9	340,4	452	702	447	350	270	196	67	M16x2	300	25	60
	300	CSE400/300-TU	572,6	17176,7	378,3	502	802	497	350	270	196	67	M16x2	300	25	60
500 /5114,32	50	CSE500/50-TU	730,6	3653,1	271,9	285	335	280	400	305	214	75	M24x3	340	36	60
	100	CSE500/100-TU	730,6	7306,2	321,7	335	435	330	400	305	214	75	M24x3	340	36	60
	150	CSE500/150-TU	730,6	10959,3	371	385	535	380	400	305	214	75	M24x3	340	36	60
	200	CSE500/200-TU	730,6	14612,3	420,8	435	635	430	400	305	214	75	M24x3	340	36	60
	250	CSE500/250-TU	730,6	18265,4	470,5	485	735	480	400	305	214	75	M24x3	340	36	60
	300	CSE500/300-TU	730,6	21918,5	519,8	535	835	530	400	305	214	75	M24x3	340	36	60
600 /5987,09	50	CSE600/50-TU	855,3	4276,5	338,9	300	350	295	430	330	244	81	M24x3	370	36	60
	100	CSE600/100-TU	855,3	8553,0	396	350	450	345	430	330	244	81	M24x3	370	36	60
	150	CSE600/150-TU	855,3	12829,5	453,5	400	550	395	430	330	244	81	M24x3	370	36	60
	200	CSE600/200-TU	855,3	17106,0	511	450	650	445	430	330	244	81	M24x3	370	36	60
	250	CSE600/250-TU	855,3	21382,5	568,1	500	750	495	430	330	244	81	M24x3	370	36	60
	300	CSE600/300-TU	855,3	25659,0	625,6	550	850	545	430	330	244	81	M24x3	370	36	60
800 /8149,09	50	CSE800/50-TU	1164,2	5820,8	530,6	340	390	335	505	385	292	95	M24x3	440	36	60
	100	CSE800/100-TU	1164,2	11641,6	610,1	390	490	385	505	385	292	95	M24x3	440	36	60
	150	CSE800/150-TU	1164,2	17462,3	689	440	590	435	505	385	292	95	M24x3	440	36	60
	200	CSE800/200-TU	1164,2	23283,1	768	490	690	485	505	385	292	95	M24x3	440	36	60
	250	CSE800/250-TU	1164,2	29103,9	847,5	540	790	535	505	385	292	95	M24x3	440	36	60
	300	CSE800/300-TU	1164,2	34924,7	926,5	590	890	585	505	385	292	95	M24x3	440	36	60
1000 /10643,72	50	CSE1000/50-TU	1520,5	7602,7	755,4	379	429	374	570	440	292	110	M24x3	500	36	60
	100	CSE1000/100-TU	1520,5	15205,3	855,8	429	529	424	570	440	292	110	M24x3	500	36	60
	150	CSE1000/150-TU	1520,5	22808,0	956,7	479	629	474	570	440	292	110	M24x3	500	36	60
	200	CSE1000/200-TU	1520,5	30410,6	1057,7	529	729	524	570	440	292	110	M24x3	500	36	60
	250	CSE1000/250-TU	1520,5	38013,3	1158,6	579	829	574	570	440	292	110	M24x3	500	36	60
	300	CSE1000/300-TU	1520,5	45616,0	1259,5	629	929	624	570	440	292	110	M24x3	500	36	60



Series
CSE GS C

Single acting cylinders with lock nut, low height for confined spaces



PRODUCT PAGE

High tonnage and confined area

CUSTOM CYLINDERS ON REQUEST



- High tonnage hydraulic cylinders with lock nut, reduced height, single acting. Push force from 60 to 500 tons with a range of strokes from 45 mm to 50 mm.
- Compact hydraulic cylinders, suitable for lifting operations pushing and heavy lifting. Lock nut for the maintenance of the load in complete safety.
- The guiding surfaces are sized to guarantee optimal performance in load offset absorption. Plugging execution, equipped with anti overstroke device.
- Equipped with high-strength gaskets for maximum durability.
- 3/8" NPT female coupler with dust cap equipped.
- Tilting saddle for optimal offset load distribution.
- Nitox ONC treatment on all mechanical components for maximum resistance against corrosion and wear.
- All models are equipped with lifting eyebolts.
- Possibility to design and produce custom made hydraulic cylinders on request, with dedicated geometries, performances and features.

CSE GS C

60-500 ton
Stroke 45-50 mm
700 bar



CSE GS C

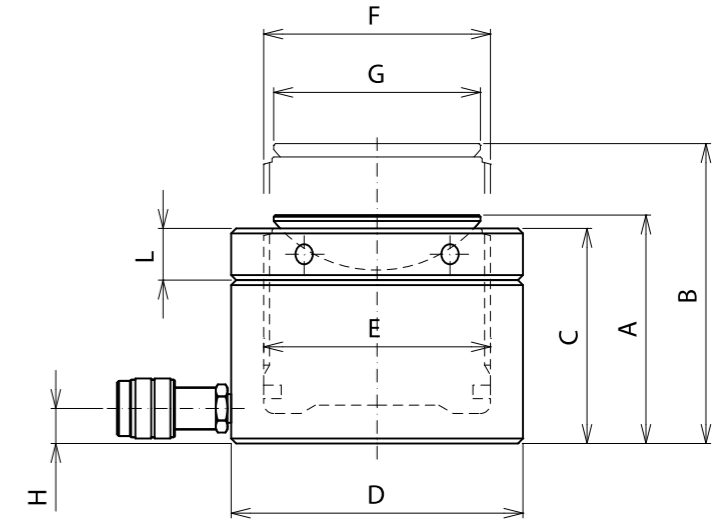

CAP/Force	STROKE	MODEL	EFFECTIVE AREA	VOLUME	MASS	DIMENSIONS (mm)								MAX SADDLE INCLINATION	
						A	B	C	D	E	F	G	H		L
ton (kN)	mm		cm ²	cm ³	kg										(°)
60 /606	50	CSE-60/50-GS-C	86,6	433	15	125	175	119	140	105	Tr 105x4	96	19	28	5
100 /1002	50	CSE-100/50-GS-C	143,1	716	24,5	137	187	129	173	135	Tr 135x6	126	21	31	5
160 /1589	45	CSE-160/45-GS-C	228	1021	42,5	148	193	139	220	170	Tr 170x6	160	27	40	5
200 /1985	45	CSE-200/45-GS-C	283,5	1276	55	155	200	145	245	190	Tr 190x6	180	30	43	5
250 /2541	45	CSE-250/45-GS-C	363,1	1634	70	159	204	147	275	215	Tr 215x6	200	32	43	5
400 /4008	45	CSE-400/45-GS-C	572,6	2576	128	178	223	166	350	270	Tr 270x6	250	40	55	4
500 /5114	45	CSE-500/45-GS-C	730,6	3288	182	192	237	182	400	305	Tr 305x6	290	49	61,5	3



Series
CSE GS TU

Single acting high tonnage cylinder, load return with lock nut



PRODUCT PAGE

High tonnage cylinders, lock nut, load return

CUSTOM CYLINDERS ON REQUEST



- High tonnage hydraulic cylinders, with lock nut, load return. Push force from 50 to 1000 ton, with range of strokes from 50 mm to 300 mm
- High tonnage hydraulic cylinders up to 3000 ton, suitable for heavy usage, lifting operations, pushing and heavy lifting.
- Plunger execution, equipped with stroke indicator and anti overstroke device.
- Lock nut for safe load upkeep. The threaded nut allows the locking and the mechanical upkeep of the load even for very long periods of time with disconnected pump. The operator then has the opportunity to work under raised load in complete safety.
- The guiding surfaces are sized to guarantee optimal performance in load offset absorption.
- 3/8" NPT female coupler with dust cap equipped.
- Removable high strength head and possibility of mounting a tilting saddle for better distribution of the load to be lifted.
- Nitox ONC treatment on all mechanical components for maximum resistance against corrosion and wear.
- All models are equipped with lifting eyebolts.
- Possibility to design and produce custom made hydraulic cylinders on request, with dedicated geometries, performances and features.

CSE GS TU

50-1000 ton
Stroke 50 - 300 mm
700 bar



CSE GS TU

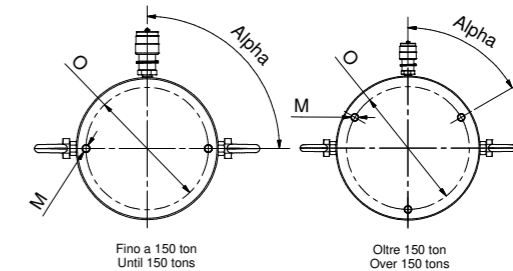
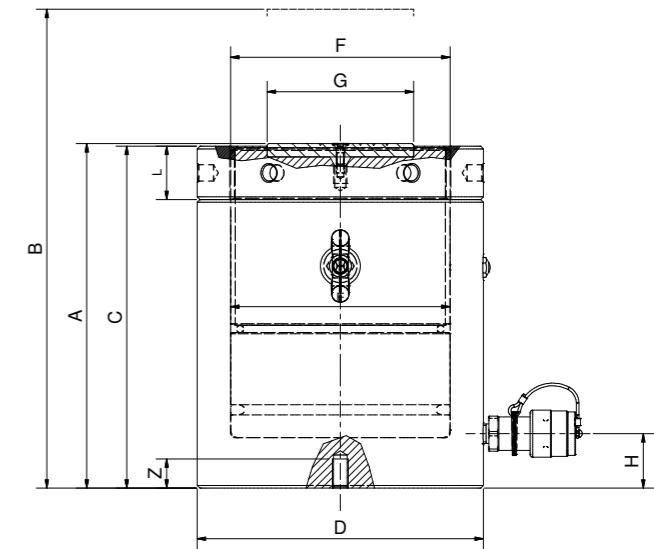

CAP/Force ton (kN)	STROKE mm	MODEL	SECTION cm ²	VOLUME cm ³	MASS kg	DIMENSIONS (mm)												
						A	B	C	D	E	F	G	H	L	M	O	Z	Alpha
50 /549,78	50	CSE50/50-GS-TU	78,5	392,7	16,9	164	214	162	130	100	Tr.100x4	72	24	25	M8x1,25	105	10	90
	100	CSE50/100-GS-TU	78,5	785,4	21,9	214	314	212	130	100	Tr.100x4	72	24	25	M8x1,25	105	10	90
	150	CSE50/150-GS-TU	78,5	1178,1	27,4	264	414	262	130	100	Tr.100x4	72	24	25	M8x1,25	105	10	90
	200	CSE50/200-GS-TU	78,5	1570,8	32,4	314	514	312	130	100	Tr.100x4	72	24	25	M8x1,25	105	10	90
	250	CSE50/250-GS-TU	78,5	1963,5	37,9	364	614	362	130	100	Tr.100x4	72	24	25	M8x1,25	105	10	90
100 /1001,97	300	CSE50/300-GS-TU	78,5	2356,2	42,9	414	714	412	130	100	Tr.100x4	72	24	25	M8x1,25	105	10	90
	50	CSE100/50-GS-TU	143,1	715,7	35,2	187	237	185	175	135	Tr.135x6	92	33	33	M12x1,75	150	22	90
	100	CSE100/100-GS-TU	143,1	1431,4	44,7	237	337	235	175	135	Tr.135x6	92	33	33	M12x1,75	150	22	90
	150	CSE100/150-GS-TU	143,1	2147,1	53,9	287	437	285	175	135	Tr.135x6	92	33	33	M12x1,75	150	22	90
	200	CSE100/200-GS-TU	143,1	2862,8	63,5	337	537	335	175	135	Tr.135x6	92	33	33	M12x1,75	150	22	90
150 /1496,77	250	CSE100/250-GS-TU	143,1	3578,5	73,1	387	637	385	175	135	Tr.135x6	92	33	33	M12x1,75	150	22	90
	300	CSE100/300-GS-TU	143,1	4294,2	82,6	437	737	435	175	135	Tr.135x6	92	33	33	M12x1,75	150	22	90
	50	CSE150/50-GS-TU	213,8	1069,1	59,4	209	259	207	215	165	Tr.165x6	110	41	40	M12x1,75	185	22	90
	100	CSE150/100-GS-TU	213,8	2138,2	73,5	259	359	257	215	165	Tr.165x6	110	41	40	M12x1,75	185	22	90
	150	CSE150/150-GS-TU	213,8	3207,4	87,7	309	459	307	215	165	Tr.165x6	110	41	40	M12x1,75	185	22	90
150 /1496,77	200	CSE150/200-GS-TU	213,8	4276,5	102,3	359	559	357	215	165	Tr.165x6	110	41	40	M12x1,75	185	22	90
	250	CSE150/250-GS-TU	213,8	5345,6	116,4	409	659	407	215	165	Tr.165x6	110	41	40	M12x1,75	185	22	90
	300	CSE150/300-GS-TU	213,8	6414,7	131	459	759	457	215	165	Tr.165x6	110	41	40	M12x1,75	185	22	90

CAP/Force	STROKE	MODEL	SECTION	VOLUME	MASS	DIMENSIONS (mm)												
ton (kN)	mm		cm ²	cm ³	kg	A	B	C	D	E	F	G	H	L	M	O	Z	Alpha
200 /1984,70	50	CSE200/50-GS-TU	283,5	1417,6	85,8	238	288	236	250	190	Tr.190x6	138	47	45	M12x1,75	215	22	60
	100	CSE200/100-GS-TU	283,5	2835,3	105,5	288	388	286	250	190	Tr.190x6	138	47	45	M12x1,75	215	22	60
	150	CSE200/150-GS-TU	283,5	4252,9	124,6	338	488	336	250	190	Tr.190x6	138	47	45	M12x1,75	215	22	60
	200	CSE200/200-GS-TU	283,5	5670,6	144,3	388	588	386	250	190	Tr.190x6	138	47	45	M12x1,75	215	22	60
	250	CSE200/250-GS-TU	283,5	7088,2	163,5	438	688	436	250	190	Tr.190x6	138	47	45	M12x1,75	215	22	60
	300	CSE200/300-GS-TU	283,5	8505,9	183,1	488	788	486	250	190	Tr.190x6	138	47	45	M12x1,75	215	22	60
250 /2541,35	50	CSE250/50-GS-TU	363,0	1815,3	119,6	249	299	247	280	215	Tr.215x6	148	53	52	M12x1,75	245	22	60
	100	CSE250/100-GS-TU	363,0	3630,5	144,3	299	399	297	280	215	Tr.215x6	148	53	52	M12x1,75	245	22	60
	150	CSE250/150-GS-TU	363,0	5445,8	168,5	349	499	347	280	215	Tr.215x6	148	53	52	M12x1,75	245	22	60
	200	CSE250/200-GS-TU	363,0	7261,0	192,7	399	599	397	280	215	Tr.215x6	148	53	52	M12x1,75	245	22	60
	250	CSE250/250-GS-TU	363,0	9076,3	217,3	449	699	447	280	215	Tr.215x6	148	53	52	M12x1,75	245	22	60
	300	CSE250/300-GS-TU	363,0	10891,5	241,5	499	799	497	280	215	Tr.215x6	148	53	52	M12x1,75	245	22	60
300 /3036,15	50	CSE300/50-GS-TU	433,7	2168,7	158,9	278	328	276	305	235	Tr.235x6	158	58	56	M16x2	260	25	60
	100	CSE300/100-GS-TU	433,7	4337,4	187,7	328	428	326	305	235	Tr.235x6	158	58	56	M16x2	260	25	60
	150	CSE300/150-GS-TU	433,7	6506,0	216,4	378	528	376	305	235	Tr.235x6	158	58	56	M16x2	260	25	60
	200	CSE300/200-GS-TU	433,7	8674,7	245,2	428	628	426	305	235	Tr.235x6	158	58	56	M16x2	260	25	60
	250	CSE300/250-GS-TU	433,7	10843,4	274,4	478	728	476	305	235	Tr.235x6	158	58	56	M16x2	260	25	60
	300	CSE300/300-GS-TU	433,7	13012,1	303,2	528	828	526	305	235	Tr.235x6	158	58	56	M16x2	260	25	60
400 /4007,89	50	CSE400/50-GS-TU	572,6	2862,8	237,4	317	367	312	350	270	Tr.270x6	196	67	65	M16x2	300	25	60
	100	CSE400/100-GS-TU	572,6	5725,6	275,3	367	467	362	350	270	Tr.270x6	196	67	65	M16x2	300	25	60
	150	CSE400/150-GS-TU	572,6	8588,3	313,2	417	567	412	350	270	Tr.270x6	196	67	65	M16x2	300	25	60
	200	CSE400/200-GS-TU	572,6	11451,1	351,6	467	667	462	350	270	Tr.270x6	196	67	65	M16x2	300	25	60
	250	CSE400/250-GS-TU	572,6	14313,9	389,5	517	767	512	350	270	Tr.270x6	196	67	65	M16x2	300	25	60
	300	CSE400/300-GS-TU	572,6	17176,7	427,4	567	867	562	350	270	Tr.270x6	196	67	65	M16x2	300	25	60
500 /5114,32	50	CSE500/50-GS-TU	730,6	3653,1	342,9	357	407	352	400	305	Tr.305x6	214	75	72	M24x3	340	36	60
	100	CSE500/100-GS-TU	730,6	7306,2	392,7	407	507	402	400	305	Tr.305x6	214	75	72	M24x3	340	36	60
	150	CSE500/150-GS-TU	730,6	10959,3	442	457	607	452	400	305	Tr.305x6	214	75	72	M24x3	340	36	60
	200	CSE500/200-GS-TU	730,6	14612,3	491,8	507	707	502	400	305	Tr.305x6	214	75	72	M24x3	340	36	60
	250	CSE500/250-GS-TU	730,6	18265,4	541,5	557	807	552	400	305	Tr.305x6	214	75	72	M24x3	340	36	60
	300	CSE500/300-GS-TU	730,6	21918,5	590,8	607	907	602	400	305	Tr.305x6	214	75	72	M24x3	340	36	60
600 /5987,09	50	CSE600/50-GS-TU	855,3	4276,5	430,1	380	430	375	430	330	Tr.330x6	244	81	80	M24x3	370	36	60
	100	CSE600/100-GS-TU	855,3	8553,0	487,2	430	530	425	430	330	Tr.330x6	244	81	80	M24x3	370	36	60
	150	CSE600/150-GS-TU	855,3	12829,5	544,7	480	630	475	430	330	Tr.330x6	244	81	80	M24x3	370	36	60
	200	CSE600/200-GS-TU	855,3	17106,0	602,2	530	730	525	430	330	Tr.330x6	244	81	80	M24x3	370	36	60
	250	CSE600/250-GS-TU	855,3	21382,5	659,3	580	830	575	430	330	Tr.330x6	244	81	80	M24x3	370	36	60
	300	CSE600/300-GS-TU	855,3	25659,0	716,8	630	930	625	430	330	Tr.330x6	244	81	80	M24x3	370	36	60
800 /8149,09	50	CSE800/50-GS-TU	1164,2	5820,8	672,1	430	480	425	505	385	Tr.385x6	292	95	90	M24x3	440	36	60
	100	CSE800/100-GS-TU	1164,2	11641,6	751,6	480	580	475	505	385	Tr.385x6	292	95	90	M24x3	440	36	60
	150	CSE800/150-GS-TU	1164,2	17462,3	830,5	530	680	525	505	385	Tr.385x6	292	95	90	M24x3	440	36	60
	200	CSE800/200-GS-TU	1164,2	23283,1	909,5	580	780	575	505	385	Tr.385x6	292	95	90	M24x3	440	36	60
	250	CSE800/250-GS-TU	1164,2	29103,9	989	630	880	625	505	385	Tr.385x6	292	95	90	M24x3	440	36	60
	300	CSE800/300-GS-TU	1164,2	34924,7	1068	680	980	675	505	385	Tr.385x6	292	95	90	M24x3	440	36	60
1000 /10643,72	50	CSE1000/50-GS-TU	1520,5	7602,7	965,7	484	534	479	570	440	Tr.440x6	292	110	105	M24x3	500	36	60
	100	CSE1000/100-GS-TU	1520,5	15205,3	1066,1	534	634	529	570	440	Tr.440x6	292	110	105	M24x3	500	36	60
	150	CSE1000/150-GS-TU	1520,5	22808,0	1167	584	734	579	570	440	Tr.440x6	292	110	105	M24x3	500	36	60
	200	CSE1000/200-GS-TU	1520,5	30410,6	1268	634	834	629	570	440	Tr.440x6	292	110	105	M24x3	500	36	60
	250	CSE1000/250-GS-TU	1520,5	38013,3	1368,9	684	934	679	570	440	Tr.440x6	292	110	105	M24x3	500	36	60
	300	CSE1000/300-GS-TU	1520,5	45616,0	1469,8	734	1034	729	570	440	Tr.440x6	292	110	105	M24x3	500	36	60



Series **CRI GS TA** | High tonnage cylinder, with lock nut, oil return



PRODUCT PAGE

High tonnage lock nut with oil return

CUSTOM CYLINDERS ON REQUEST



- High tonnage hydraulic cylinders with lock nut, oil return, with rapid hydraulic return, high pressure. Push force from 30 to 600 tons with range of strokes from 50 mm to 300 mm on customer request.
- High tonnage hydraulic cylinders up to 3.000 ton, suitable for heavy usage, lifting operations, pushing and heavy lifting.
- Lock nut for safe load upkeep. The threaded nut allows the locking and the mechanical upkeep of the load even for very long periods of time with disconnected pump. The operator then has the opportunity to work under raised load in complete safety.
- The guiding surfaces are sized to guarantee optimal performance in load offset absorption and the stop ring increases safety for the operator avoiding the extra stroke of piston.
- Equipped with high-strength gaskets for maximum durability.
- 3/8" NPT female coupler with dust cap equipped.
- Integrated high strength tilting saddle for better distribution of the load to be lifted.
- Nitox ONC treatment on all mechanical components for maximum resistance against corrosion and wear.
- All models are equipped with lifting eyebolts.

CRI GS TA

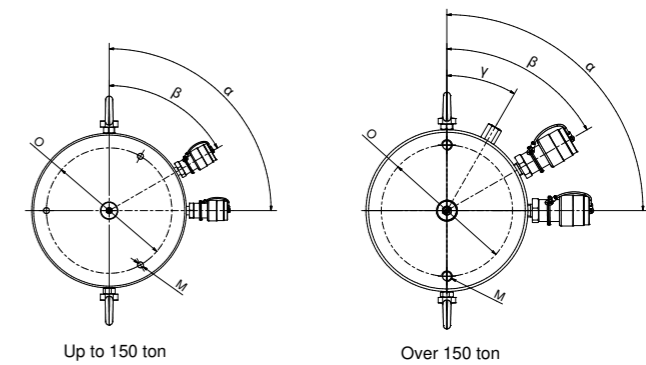
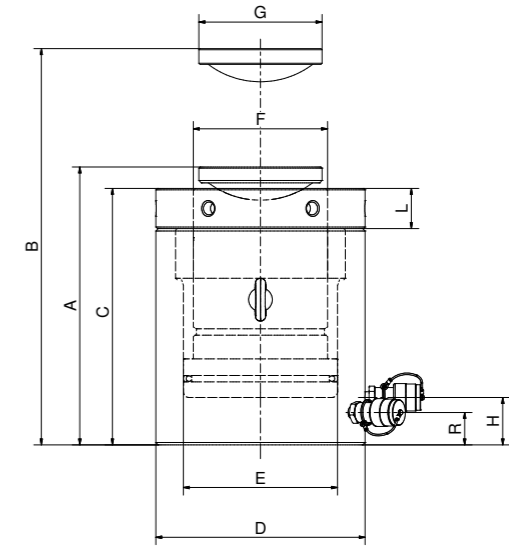

CAP/Force	STROKE	MODEL	SECTION cm ²		VOLUME		MASS	DIMENSIONS (mm)													MAX SADDLE INCLINATION		
			Push	Pull	Push	Pull		kg	A	B	C	D	E	F	G	H	L	M	O	R		Alpha (°)	Beta (°)
50 /500,30	100	CRI-50-100-GS TA	71,47	16,69	714,71	166,90	27	277	377	256	135	100	TR85X6	96	45	28	M12x1,75	105	30,8	90	60	30	5
	150	CRI-50-150-GS TA	71,47	16,69	1072,07	250,35	31	327	477	306	135	100	TR85X6	96	45	28	M12x1,75	105	30,8	90	60	30	5
	200	CRI-50-200-GS TA	71,47	16,69	1429,42	333,79	35	377	577	356	135	100	TR85X6	96	45	28	M12x1,75	105	30,8	90	60	30	5
	250	CRI-50-250-GS TA	71,47	16,69	1786,78	417,24	39,5	427	677	406	135	100	TR85X6	96	45	28	M12x1,75	105	30,8	90	60	30	5
	300	CRI-50-300-GS TA	71,47	16,69	2144,14	500,69	43,5	477	777	456	135	100	TR85X6	96	45	28	M12x1,75	105	30,8	90	60	30	5
100 /1028,09	100	CRI-100-100-GS TA	146,87	16,69	1468,69	166,90	55	299	399	275	185	140	TR120X6	116	45	38	M12x1,75	150	30,8	90	60	30	5
	150	CRI-100-150-GS TA	146,87	16,69	2203,04	250,35	63,5	349	499	325	185	140	TR120X6	116	45	38	M12x1,75	150	30,8	90	60	30	5
	200	CRI-100-200-GS TA	146,87	16,69	2937,39	333,79	76	419	619	395	185	140	TR120X6	116	45	38	M12x1,75	150	30,8	90	60	30	5
	250	CRI-100-250-GS TA	146,87	16,69	3671,74	417,24	84	469	719	445	185	140	TR120X6	116	45	38	M12x1,75	150	30,8	90	60	30	5
150 /1500,90	100	CRI-150-100-GS TA	214,41	20,62	2144,14	206,17	87,5	316	416	290	225	170	TR145X6	146	51	44	M12x1,75	185	35,5	90	60	30	5
	150	CRI-150-150-GS TA	214,41	20,62	3216,21	309,25	99,5	366	516	340	225	170	TR145X6	146	51	44	M12x1,75	185	35,5	90	60	30	5
	200	CRI-150-200-GS TA	214,41	20,62	4288,27	412,33	117	434	634	408	225	170	TR145X6	146	51	44	M12x1,75	185	35,5	90	60	30	5
	250	CRI-150-250-GS TA	214,41	20,62	5360,34	515,42	130	484	734	458	225	170	TR145X6	146	51	44	M12x1,75	185	35,5	90	60	30	5
	300	CRI-150-300-GS TA	214,41	20,62	6432,41	618,50	142,5	534	834	508	225	170	TR145X6	146	51	44	M12x1,75	185	35,5	90	60	30	5

CAP/Force	STROKE	MODEL	SECTION cm ²		VOLUME		MASS	DIMENSIONS (mm)													MAX SADDLE INCLINATION		
			Push	Pull	Push	Pull		kg	A	B	C	D	E	F	G	H	L	M	O	R		Alpha (°)	Beta (°)
200 /2002,57	100	CRI-200-100-GS TA	286,08	44,18	2860,81	441,79	134	352	452	325	265	195	TR170X6	156	60	51	M12x1,75	215	41	90	60	-	5
	150	CRI-200-150-GS TA	286,08	44,18	4291,22	662,68	151,5	402	552	375	265	195	TR170X6	156	60	51	M12x1,75	215	41	90	60	-	5
	200	CRI-200-200-GS TA	286,08	44,18	5721,63	883,57	176	469	669	442	265	195	TR170X6	156	60	51	M12x1,75	215	41	90	60	-	5
	250	CRI-200-250-GS TA	286,08	44,18	7152,03	1104,47	193	519	769	492	265	195	TR170X6	156	60	51	M12x1,75	215	41	90	60	-	5
	300	CRI-200-300-GS TA	286,08	44,18	8582,44	1325,36	210	569	869	542	265	195	TR170X6	156	60	51	M12x1,75	215	41	90	60	-	5
250 /2453,39	100	CRI-250-100-GS TA	350,48	44,18	3504,84	441,79	172	370	470	340	290	215	TR190X6	194	60	58	M12x1,75	245	41	90	60	-	5
	150	CRI-250-150-GS TA	350,48	44,18	5257,26	662,68	193	420	570	390	290	215	TR190X6	194	60	58	M12x1,75	245	41	90	60	-	5
	200	CRI-250-200-GS TA	350,48	44,18	7009,68	883,57	225	490	690	460	290	215	TR190X6	194	60	58	M12x1,75	245	41	90	60	-	5
	250	CRI-250-250-GS TA	350,48	44,18	8762,10	1104,47	246	540	790	510	290	215	TR190X6	194	60	58	M12x1,75	245	41	90	60	-	5
	300	CRI-250-300-GS TA	350,48	44,18	10514,52	1325,36	266	590	890	560	290	215	TR190X6	194	60	58	M12x1,75	245	41	90	60	-	5
300 /2948,19	100	CRI-300-100-GS TA	421,17	44,18	4211,70	441,79	206	374	474	344	315	235	TR205X6	210	60	60	M16x2	260	41	90	60	-	5
	150	CRI-300-150-GS TA	421,17	44,18	6317,55	662,68	230	424	574	394	315	235	TR205X6	210	60	60	M16x2	260	41	90	60	-	5
	200	CRI-300-200-GS TA	421,17	44,18	8423,40	883,57	268,5	496	696	466	315	235	TR205X6	210	60	60	M16x2	260	41	90	60	-	5
	250	CRI-300-250-GS TA	421,17	44,18	10529,24	1104,47	293	546	796	516	315	235	TR205X6	210	60	60	M16x2	260	41	90	60	-	5
	300	CRI-300-300-GS TA	421,17	44,18	12635,09	1325,36	318	596	896	566	315	235	TR205X6	210	60	60	M16x2	260	41	90	60	-	5
400 /4020,26	100	CRI-400-100-GS TA	574,32	75,40	5743,22	753,98	321	438	538	408	365	275	TR230X6	210	85	75	M18x2,5	280	62,5	90	60	-	5
	150	CRI-400-150-GS TA	574,32	75,40	8614,84	1130,97	352,5	488	638	458	365	275	TR230X6	210	85	75	M18x2,5	280	62,5	90	60	-	5
	200	CRI-400-200-GS TA	574,32	75,40	11486,45	1507,96	402	560	760	530	365	275	TR230X6	210	85	75	M18x2,5	280	62,5	90	60	-	5
	250	CRI-400-250-GS TA	574,32	75,40	14358,06	1884,96	433	610	860	580	365	275	TR230X6	210	85	75	M18x2,5	280	62,5	90	60	-	5
	300	CRI-400-300-GS TA	574,32	75,40	17229,67	2261,95	464	660	960	630	365	275	TR230X6	210	85	75	M18x2,5	280	62,5	90	60	-	5
500 /4976,87	100	CRI-500-100-GS TA	710,98	75,40	7109,82	753,98	406	459	559	427	400	305	TR250X6	240	85	85	M18x2,5	320	62,5	90	60	-	5
	150	CRI-500-150-GS TA	710,98	75,40	10664,73	1130,97	443	509	659	477	400	305	TR250X6	240	85	85	M18x2,5	320	62,5	90	60	-	5
	200	CRI-500-200-GS TA	710,98	75,40	14219,63	1507,96	505	584	784	552	400	305	TR250X6	240	85	85	M18x2,5	320	62,5	90	60	-	5
	250	CRI-500-250-GS TA	710,98	75,40	17774,54	1884,96	542	634	884	602	400	305	TR250X6	240	85	85	M18x2,5	320	62,5	90	60	-	5
	300	CRI-500-300-GS TA	710,98	75,40	21329,45	2261,95	579	684	984	652	400	305	TR250X6	240	85	85	M18x2,5	320	62,5	90	60	-	5





PRODUCT
PAGE

High tonnage
Oil return

CUSTOM CYLINDERS ON REQUEST



- High tonnage hydraulic cylinders, double acting, oil return, high pressure. Push force from 30 to 1000 ton, with range of strokes from 160 mm to 330 mm.
- Extremely versatile hydraulic cylinders, hydraulic return allows shorter return times also in all conditions of usage, suitable for lifting operations and for heavy-duty applications.
- The guiding surfaces are sized to guarantee optimal performance in load offset absorption and the stop ring increases safety for the operator avoiding the extra stroke of piston. 10 % side load resistance .
- Equipped with high strength gaskets for maximum durability.
- 3/8" NPT female coupler with dust cap equipped.
- Removable high strength head and possibility of mounting a tilting saddle for better distribution of the load to be lifted.
- Nitox ONC treatment on all mechanical components for maximum resistance against corrosion and wear.
- All models are equipped with lifting eyebolts.
- Possibility to design and produce custom made hydraulic cylinders on request, with dedicated geometries, performances and features.



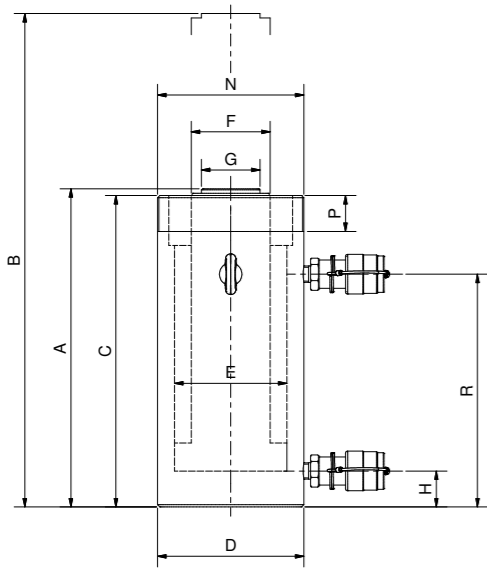

CRI-C

30-1000 ton
Stroke 50-300 mm
700 bar

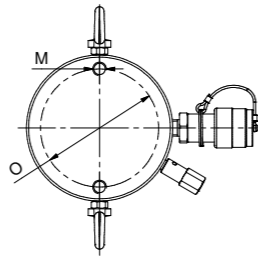

CRI-C

CAP/Force ton (kN)	STROKE mm	MODEL	SECTION cm ²		VOLUME cm ³		MASS kg	DIMENSIONS (mm)												
			Push	Pull	Push	Pull		A	B	C	D	E	F	G	H	M	N	O	P	R
30 /309,2	30	CRI-30/160	44,1	15,9	706,8	254,5	20,6	292	452	280	113	75	60	58	32	2xM10	M112x2	50	35	223
	30	CRI-30/260	44,1	15,9	1148,6	413,5	27,5	392	652	380	113	75	60	58	32	2xM10	M112x2	50	35	223
50 /496,2	50	CRI-C-50/50	70,9	32,4	354,5	162	17,7	183	233	177	130	95	70	52	32	2xM12	M130x2	105	32	107
	100	CRI-C-50/100	70,9	32,4	708,8	324	21,6	233	333	227	130	95	70	52	32	2xM12	M130x2	105	32	157
	150	CRI-C-50/150 (*)	70,9	32,4	1063,2	486	25,5	283	433	277	130	95	70	52	32	2xM12	M130x2	105	32	207
	200	CRI-C-50/200	70,9	32,4	1417,6	648	30,5	343	543	337	130	95	70	52	32	2xM12	M130x2	105	32	267
	250	CRI-C-50/250	70,9	32,4	1772	810	34,5	393	643	387	130	95	70	52	32	2xM12	M130x2	105	32	317
300	CRI-C-50/300 (*)	70,9	32,4	2126,4	972	38,4	443	743	437	130	95	70	52	32	2xM12	M130x2	105	32	367	
100 /1002	50	CRI-C-100/50	143,1	64,6	715,7	323	35	202	252	194	175	135	100	92	36	2xM12	M175x3	150	46	126,5
	100	CRI-C-100/100	143,1	64,6	1431,4	646	42	252	352	244	175	135	100	92	36	2xM12	M175x3	150	46	176,5
	150	CRI-C-100/150	143,1	64,6	2147,1	969	48,8	302	452	294	175	135	100	92	36	2xM12	M175x3	150	46	226,5
	200	CRI-C-100/200	143,1	64,6	2862,8	1292	60,4	378	578	370	175	135	100	92	36	2xM12	M175x3	150	46	288,5
	250	CRI-C-100/250	143,1	64,6	3578,5	1615	67,3	428	678	420	175	135	100	92	36	2xM12	M175x3	150	46	338,5
300	CRI-C-100/300	143,1	64,6	4294,2	1938	74	478	778	470	175	135	100	92	36	2xM12	M175x3	150	46	388,5	
150 /1497	50	CRI-C-150/50	213,8	100,7	1069	503,5	57	220	270	213	215	165	120	110	46	2xM12	M215x3	185	52	138
	100	CRI-C-150/100	213,8	100,7	2138	1007	68	270	370	263	215	165	120	110	46	2xM12	M215x3	185	52	188
	150	CRI-C-150/150	213,8	100,7	3207	1510,5	79	320	470	313	215	165	120	110	46	2xM12	M215x3	185	52	238
	200	CRI-C-150/200	213,8	100,7	4276	2014	96	397	597	390	215	165	120	110	46	2xM12	M215x3	185	52	299
	250	CRI-C-150/250	213,8	100,7	5345	2517,5	107	447	697	440	215	165	120	110	46	2xM12	M215x3	185	52	349
300	CRI-C-150/300	213,8	100,7	6414	3021	117	497	797	490	215	165	120	110	46	2xM12	M215x3	185	52	399	
200 /1985	50	CRI-C-200/50	283,5	106,8	1417,5	534	83	231	281	224	250	190	150	138	50	3xM12	M250x3	215	57	146
	100	CRI-C-200/100	283,5	106,8	2835	1068	98	281	381	274	250	190	150	138	50	3xM12	M250x3	215	57	196
	150	CRI-C-200/150	283,5	106,8	4252,5	1602	111	331	481	324	250	190	150	138	50	3xM12	M250x3	215	57	246
	200	CRI-C-200/200	283,5	106,8	5670	2136	139	408	608	401	250	190	150	138	50	3xM12	M250x3	215	57	309
	250	CRI-C-200/250	283,5	106,8	7087,5	2670	154	458	708	451	250	190	150	138	50	3xM12	M250x3	215	57	359
300	CRI-C-200/300	283,5	106,8	8505	3204	169	508	808	501	250	190	150	138	50	3xM12	M250x3	215	57	409	

CAP/Force ton (kN)	STROKE mm	MODEL	SECTION cm ²		VOLUME cm ³		MASS kg	DIMENSIONS (mm)												
			Push	Pull	Push	Pull		A	B	C	D	E	F	G	H	M	N	O	P	R
250 /2541	50	CRI-C-250/50	363,1	136,1	1815,5	680,5	109	241	291	235	280	215	170	148	55	3xM12	M280x3	245	57	153
	100	CRI-C-250/100	363,1	136,1	3631	1361	128	291	391	285	280	215	170	148	55	3xM12	M280x3	245	57	203
	150	CRI-C-250/150	363,1	136,1	5446,5	2041,5	147	341	491	335	280	215	170	148	55	3xM12	M280x3	245	57	253
	200	CRI-C-250/200	363,1	136,1	7262	2722	185	431	631	425	280	215	170	148	55	3xM12	M280x3	245	57	319
	250	CRI-C-250/250	363,1	136,1	9077,5	3402,5	204	481	731	475	280	215	170	148	55	3xM12	M280x3	245	57	369
300	CRI-C-250/300	363,1	136,1	10893	4083	224	531	831	525	280	215	170	148	55	3xM12	M280x3	245	57	419	
300 /3036	50	CRI-C-300/50	433,7	119,6	2168,5	598	159	296	346	292	305	235	200	158	58	3xM16	M305x3	260	73	191
	100	CRI-C-300/100	433,7	119,6	4337	1196	183	346	446	342	305	235	200	158	58	3xM16	M305x3	260	73	241
	150	CRI-C-300/150	433,7	119,6	6505,5	1794	208	396	546	392	305	235	200	158	58	3xM16	M305x3	260	73	291
	200	CRI-C-300/200	433,7	119,6	8674	2392	232	446	646	442	305	235	200	158	58	3xM16	M305x3	260	73	341
	250	CRI-C-300/250	433,7	119,6	10842,5	2990	257	496	746	492	305	235	200	158	58	3xM16	M305x3	260	73	391
300	CRI-C-300/300	433,7	119,6	13011	3588	281	546	846	542	305	235	200	158	58	3xM16	M305x3	260	73	441	
400 /4008	50	CRI-C-400/50	572,6	192,4	2863	962	227	321	371	317	350	270	220	196	74	3xM16	M350x3	300	83	206
	100	CRI-C-400/100	572,6	192,4	5726	1924	258	371	471	367	350	270	220	196	74	3xM16	M350x3	300	83	256
	150	CRI-C-400/150	572,6	192,4	8589	2886	289	421	571	417	350	270	220	196	74	3xM16	M350x3	300	83	306
	200	CRI-C-400/200	572,6	192,4	11452	3848	321	471	671	467	350	270	220	196	74	3xM16	M350x3	300	83	356
	250	CRI-C-400/250	572,6	192,4	14315	4810	352	521	771	517	350	270	220	196	74	3xM16	M350x3	300	83	406
300	CRI-C-400/300	572,6	192,4	17178	5772	383	571	871	567	350	270	220	196	74	3xM16	M350x3	300	83	456	
500 /5114	50	CRI-C-500/50	730,6	239,7	3653	1198,5	320	344	394	340	400	305	250	214	79	3xM24	M400x4	340	90	219
	100	CRI-C-500/100	730,6	239,7	7306	2397	361	394	494	390	400	305	250	214	79	3xM24	M400x4	340	90	269
	150	CRI-C-500/150	730,6	239,7	10959	3595,5	402	444	594	440	400	305	250	214	79	3xM24	M400x4	340	90	319
	200	CRI-C-500/200	730,6	239,7	14612	4794	443	494	694	490	400	305	250	214	79	3xM24	M400x4	340	90	369
	250	CRI-C-500/250	730,6	239,7	18265	5992,5	484	544	794	540	400	305	250	214	79	3xM24	M400x4	340	90	419
300	CRI-C-500/300	730,6	239,7	21918	7191	525	594	894	590	400	305	250	214	79	3xM24	M400x4	340	90	469	
600 /5987	50	CRI-C-600/50	855,3	282,7	4276,5	1413,5	379	352	402	348	430	330	270	244	85	3xM24	M430x4	370	90	227
	100	CRI-C-600/100	855,3	282,7	8553	2827	427	402	502	398	430	330	270	244	85	3xM24	M430x4	370	90	277
	150	CRI-C-600/150	855,3	282,7	12829,5	4240,5	474	452	602	448	430	330	270	244	85	3xM24	M430x4	370	90	327
	200	CRI-C-600/200	855,3	282,7	17106	5654	521	502	702	498	430	330	270	244	85	3xM24	M430x4	370	90	377
	250	CRI-C-600/250	855,3	282,7	21382,5	7067,5	568	552	802	548	430	330	270	244	85	3xM24	M430x4	370	90	427
300	CRI-C-600/300	855,3	282,7	25659	8481	615	602	902	598	430	330	270	244	85	3xM24	M430x4				

Accessories for cylinders

Series **TAL | TFO | TPO | TFF**
DEO | DEP | DEF | DEA

MODEL	CYLINDER MODEL	A	B	C	D	E	WEIGHT Kg
TFO 10	CRM 10	34	37	1" - 8 UN	12	33	0,2
TFO 15	CRM 15	39	41	1" - 8 UN	15	36	0,3
TFO 25	CRM 25	52	53	1 1/2" - 16 UN	15	44	0,5
TFO 30	CRM 30	54	58	1 1/2" - 16 UN	15	46	0,6
TAL 30	CRI 30	54	57	28	18	49,5	0,7

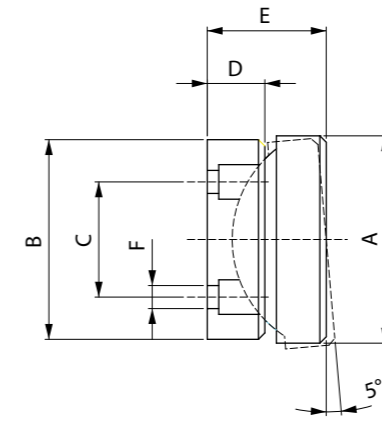

TPO

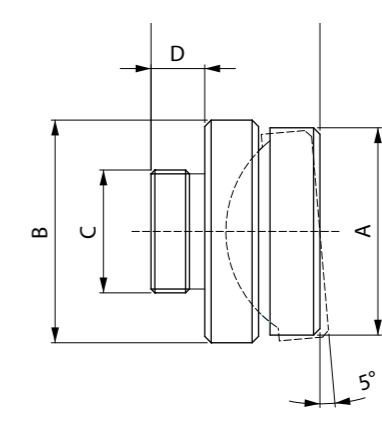

TAL-TFO

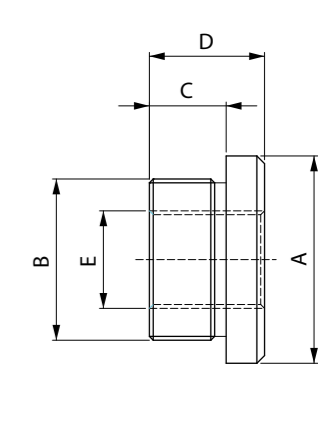

TTF

MODEL	CYLINDER MODEL	A	B	C	D	E	F	WEIGHT Kg
TPO 30	CRMA 30 - CRI-C 50	54	52	30	15	31	5,5 (N°2)	0,45
TPO 50	CSE-50-TU - CSE-50-GS-TU - CRM 50 - CRMA 50	66	72	50	17	35	6,5 (N°2)	0,85
TPO 100	CSE-100-TU - CSE-100-GS-TU - CRM 100 - CRMA 100 - CRI-C 100	96	92	50	22	43	6,5 (N°2)	1,9
TPO 150	CSE-150-TU - CSE-150-GS-TU - CRI-C 150	116	110	70	21	45	6,5 (N°2)	2,8
TPO 200	CSE-200-TU - CSE-200-GS-TU - CRI-C 200	136	138	90	25	51	6,5 (N°2)	5,2
TPO 250	CSE-250-TU - CSE-250-GS-TU - CRI-C 250	146	148	90	25	51	6,5 (N°2)	6
TPO 300	CSE-300-TU - CSE-300-GS-TU - CRI-C 300	156	158	120	25	52	6,5 (N°2)	6,9
TPO 400	CSE-400-TU - CSE-400-GS-TU - CRI-C 400	194	196	160	25	55	8,5 (N°2)	12,2
TPO 500	CSE-500-TU - CSE-500-GS-TU - CRI-C 500	210	214	170	25	55	8,5 (N°2)	14,5
TPO 600	CSE-600-TU - CSE-600-GS-TU - CRI-C 600	240	244	210	27	59	8,5 (N°2)	21,2
TPO 800	CSE-800-TU - CSE-800-GS-TU - CRI-C 800 - CSE-1000-TU - CSE-1000-GS-TU - CRI-C 1000	288	292	250	32	72	10,5 (N°2)	32,4

* Models TPO 10 and TPO 20 are available for out-of-print cylinders

MODEL	CYLINDER MODEL	A	B	C	D	E	WEIGHT Kg
TFF 10	CRM10/**FO	Ø 34,5	M28x1,5	15	20	M18x2,5	0,1
TFF 20	CRM20/**FO	Ø 44,5	M35x1,5	15	23	1" - 8 UNC	0,29
TFF 30	CRM30/**FO CRI30/**FO	Ø 57	M45x2	29	36	1" 1/4-7 UNC	0,35
TFF 60	CRM60/**FO CRI60/**FO	Ø 90	M72x1,5	29	37	1" 5/8-51/2 UNS	1,00
TFF 100	CRM100/**FO CRI100/**FO	Ø 125	M105x2	31	40	M76x6	1,50
TFF 150	CRI150/**FO	Ø 139	M105x2	43	57	M80x6	2,8

Model	Cylinder model	DIMENSIONS (mm)									
		D	D1	D2	A	B	C	E	F	G	Weight kg
DEO 5	CDE 5	M35X1,5	M20X1,5	16	20	23	67	14	34	16	0,3
DEO 10	CDE 10	M48X1,5	M24X2	19	20	23	77	19	42	25	1,03
DEO 14	CDE 14	M56X1,5	M27X2	25	27	28	98	25	54	32	2,2
DEO 22	CDE 22	M70X2	M40X2	32	29	30	112	32	66	38	4,7
DEO 30	CDE 30	M80X2	M50X2	38	30	31	130	38	80	42	6,9

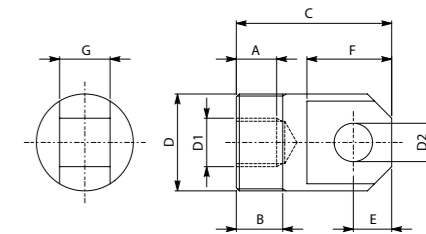

DEO

Model	Cylinder model	DIMENSIONS (mm)						
		D	D1	A	B	C	E	Weight kg
DEP 5	CDE 5	42	10.5	84	60	15	64	0.3
DEP 10	CDE 10	60	13	110	84	25	84	1.03
DEP 14	CDE 14	70	17	136	100	35	100	2.2
DEP 22	CDE 22	85	23	170	130	45	124	4.7
DEP 30	CDE 30	105	25	200	150	50	148	6.9

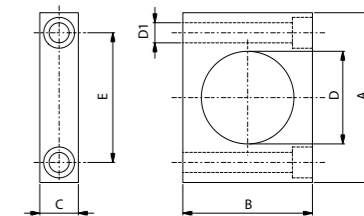

DEP

Model	Cylinder model	DIMENSIONS (mm)					
		D	D1	D2	D3	A	Weight kg
DEF 5	CDE 5	98	42	8.5	75	18	0.75
DEF 10	CDE 10	125	60	10.5	100	23	1.55
DEF 14	CDE 14	145	70	13	116	36	3.35
DEF 22	CDE 22	175	85	17	138	45	6
DEF 30	CDE 30	199	105	19	165	50	7.9

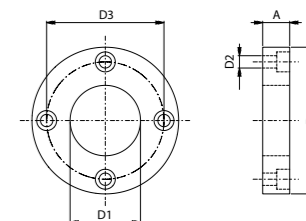

DEF

Model	Cylinder model	DIMENSIONS (mm)			
		D	D1	A	Weight kg
DEA 5	CDE 5	60	M42X1.5	9	0.1
DEA 10	CDE 10	80	M60X2	12	0.2
DEA 14	CDE 14	94	M70X2	16	0.35
DEA 22	CDE 22	110	M85X2	20	0.65
DEA 30	CDE 30	135	M105X2	22	1.05

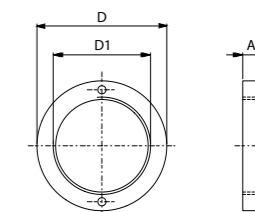

DEA

F.P.T. / HAND PUMPS





FROM 700 TO 4.000 bar



02/

INDEX

HAND PUMPS

	Oiltank capacity (litres)	cm ³ /stroke	Series		PAGE
Single speed	0,7-4	3	PMSA		66
Two speed	1-9	122-4,8	PDSA		68
Two speed for double acting cylinder	1,8-9	122-4,8	PDSA DE		70
Very high pressure 1600 - 3000 - 4000 bar	1,8	40-1	PMSA PDSA		72

F.P.T. / HAND PUMPS

FROM 700 TO 4.000 bar

High pressure hand pumps produced in light aluminum alloy of aeronautics grade to minimize weight. Operating pressure from 700 to 4.000 bar.

Used in multiple fields of application, they represent an important tool, essential wherever there is no source of energy.

ALUMINUM ALLOY OF AERONAUTICS GRADE LIGHTWEIGHT AND EXTREMELY TOUGH

The use of this type of material reduces weights of the pump and the fatigue of the operator to their lowest increasing the handling and portability, even in environments that are difficult to reach. Designed to withstand critical conditions of work, fast and with low effort on the lever. The ideal tool.

CUSTOM HAND PUMPS ON CUSTOMER'S REQUEST

On request:

- Viton - Ethylene propylene special gaskets
- Various oil tank capacities available
- Customizable with additional relief valves.
- For hydrostatic tests with fluids different from oil.
- Dimensions, fixing holes, valve blocks to customer specification.

H₂O HAND PUMPS – WATER FLUID USE

FPT produces a range of hand pumps that can be used with water. This choice is a solution that protects the environment and can be used anywhere as the water is an eco-friendly fluid. It can therefore be operated in any environment. The H₂O series is very popular in laboratories for pressure testing, on-site tests and in all those situations where contamination with oil is not allowed.

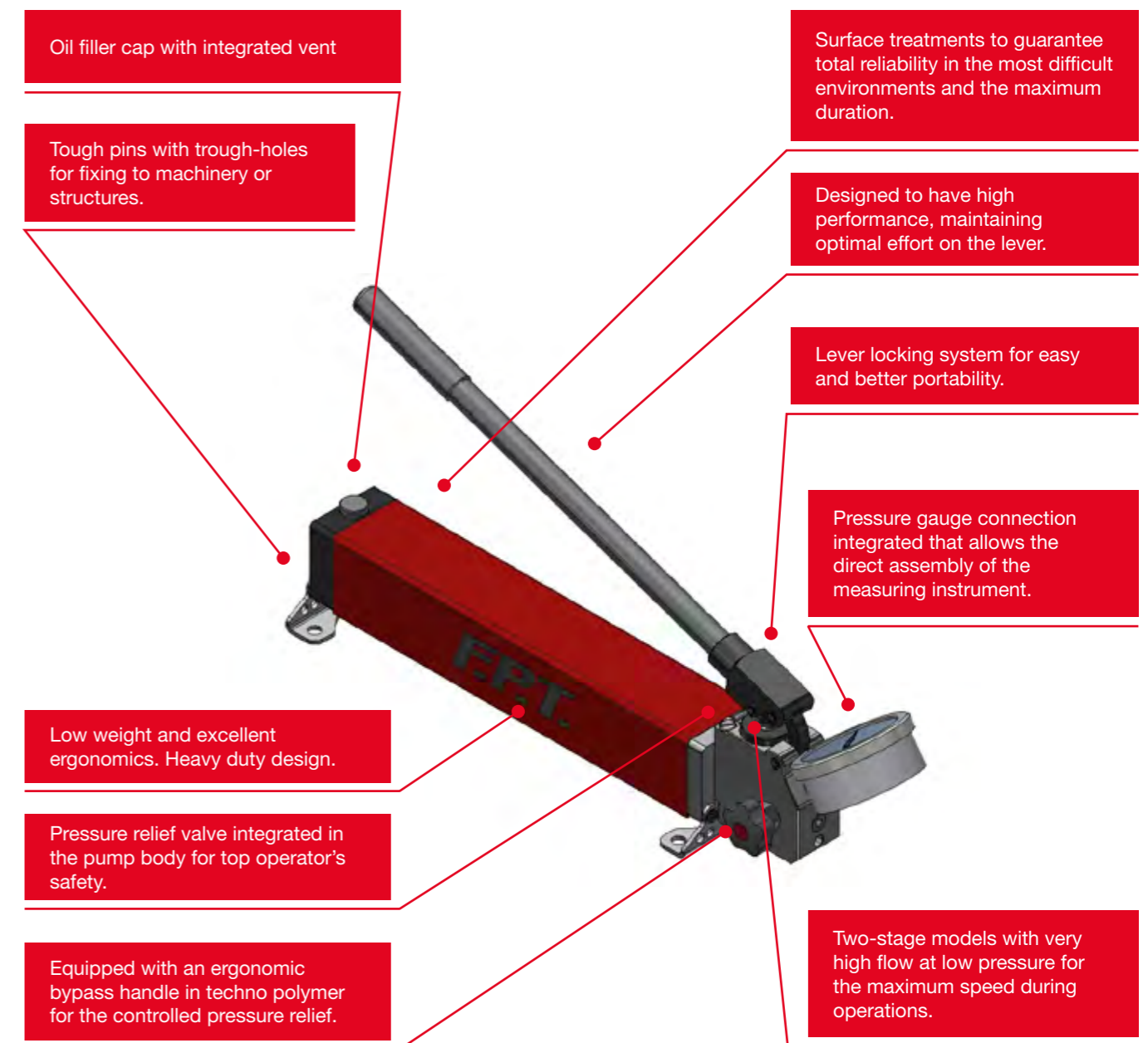

PUMP CODE DESCRIPTION

The coding table of the hand pumps shows the various possibilities of range, choice of materials, type of drive and tank capacities available. This table, in addition to the request for costum pumps, may be useful to identify an F.P.T. hand pump in your possession and request spare parts or a new one.

PMS	A	40	DE	L4	V
PMS – SINGLE SPEED PUMP PDS – DOUBLE SPEED PUMP PS – SINGLE PISTON	A – ALUMINIUM H ₂ O – STAINLESS STEEL 	OIL FLOW cm ³ /STROKE	DE – DOUBLE ACTING FC – FOOT CONTROL	OIL TANK CAPACITY (litres)	V – VITON EP – ETHYLENE PROPYLENE
					FOR SPECIAL PUMPS customer identification

Series **PMSA** | Single speed hand pump aluminium



PRODUCT PAGE

Compact and light weight

CUSTOM PUMPS ON REQUEST

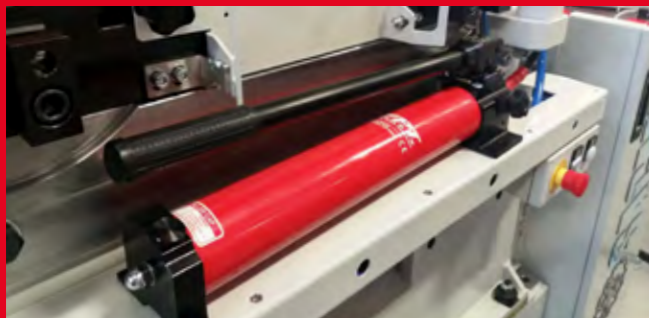

- High pressure hand pumps manufactured in light alloy aluminum of aeronautical grade to minimize the weight.
- Single stage version with a maximum flow rate of 3 cc per stroke suitable for single acting applications.
- Pressure relief valve integrated in the pump body for maximum operator safety.
- High performance, low weight and excellent ergonomics.
- Integrated pressure gauge connection for direct assembly of measuring instrument.
- Oil filler cap with integrated breather. Tough pins with trough-holes for attachment to machinery or structures.
- Surface treatments to guarantee total reliability in the most difficult environments and maximum duration.

PMSA

700 bar
3 cm³ oil flow
0,7 - 4 l capacity

PMSA-2

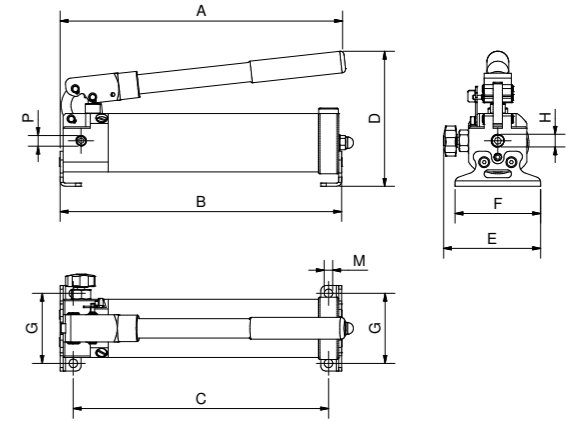

PMSA-3

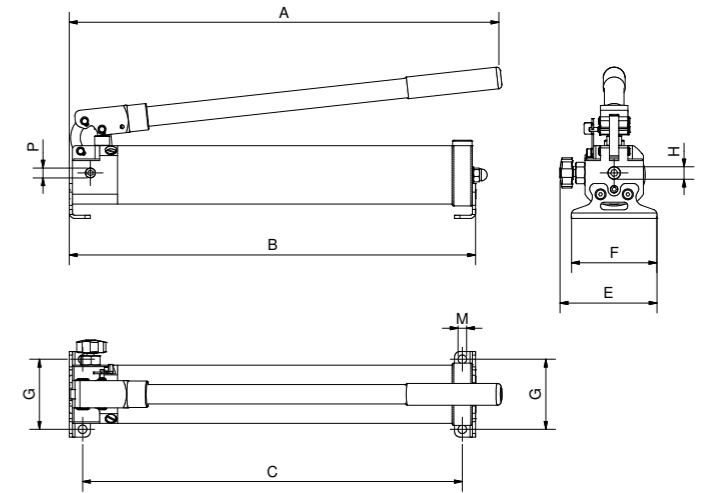

PMSA-3/L3

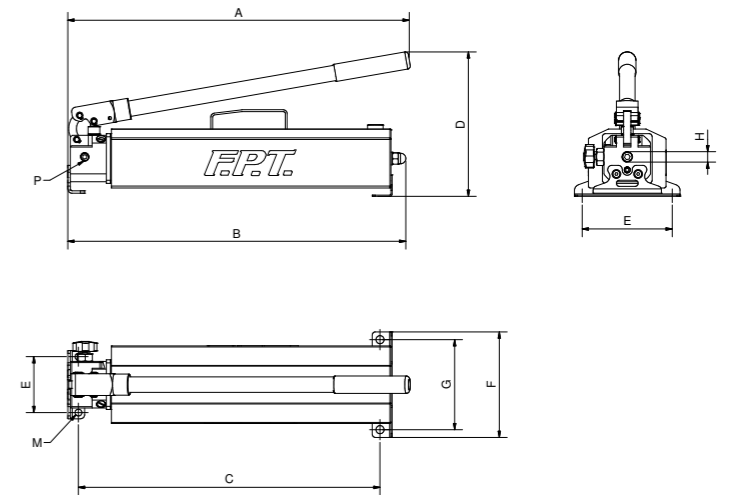

MODEL	PRESSURE max bar	OIL DISPLACEMENT STROKE cm ³	RESERVOIR CAPACITY litres	USABLE OIL litres	DIMENSIONS (mm)										WEIGHT kg
					A	B	C	D	E	F	G	H	M	P	
PMSA - 2	700	2	0,7	0,5	367	362	328	175	124,5	110	90	3/8" NPT	11	1/4" NPT	3,5
PMSA - 3	700	3	1,3	1	555	522	488	195	135	110	90	3/8" NPT	11	1/4" NPT	4,6
PMSA - 3/L3	700	3	4	3	556	544	485,5	233	90	170	145	3/8" NPT	13	1/4" NPT	8,5

Series **PDSA** | Two speed hand pump aluminium



PRODUCT PAGE

For the maximum speed during operations

CUSTOM PUMPS ON REQUEST



- High pressure hand pumps manufactured in light alloy of aeronautical grade aluminum to minimize the weight.
- Two speed version first stage 40 cc flow rate for rapid approach and 3 cc at the second stage. For maximum speed during operations.
- Pressure relief valve integrated in the pump body for maximum operator safety.
- High performance, low weight and excellent ergonomics.
- Integrated pressure gauge connection for direct assembly of measuring instrument.
- Oil filler cap with integrated breather. Tough pins with trough-holes for attachment to machinery or structures.
- Surface treatments to guarantee total reliability in the most difficult environments and maximum duration.

PDSA

700 bar
122 - 2,6 cm³ oil flow
1 - 9 l capacity

PDSA 40C
PDSA-40

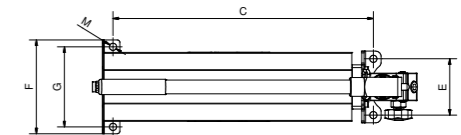
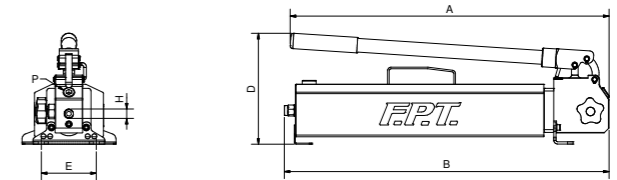
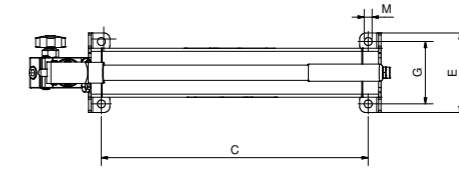
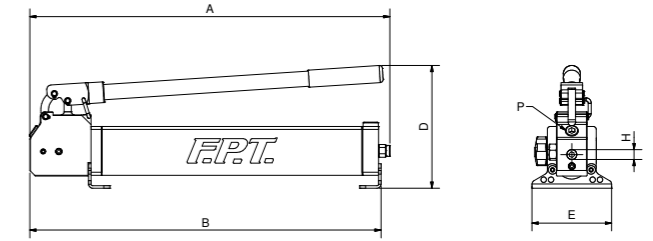

PDSA-40 L4/L8

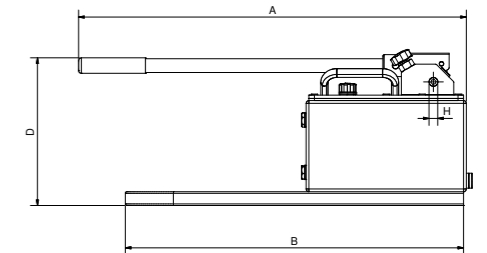
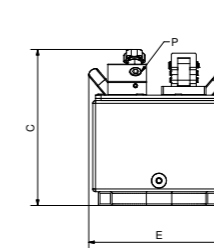

PDS-120-SE

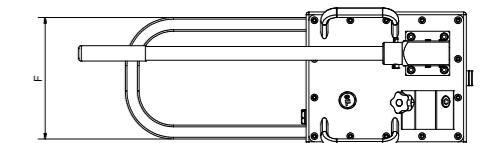

MODEL	PRESSURE	OIL FLOW	RESERVOIR	USABLE	DIMENSIONS (mm)										WEIGHT
	1 ST /2 ND STAGE	1 ST /2 ND STAGE	CAPACITY	OIL	A	B	C	D	E	F	G	H	M	P	
	bar	cm ³	litres	litres											
PDSA-40C	25/700	40/1	1	0,9	392,5	378	240	190	130	130	102	3/8"NPT	13	G 1/2"	5,5
PDSA - 40	25/700	40/3	1,8	1,6	590	477	435	200	130	130	102	3/8" NPT	13	G 1/2"	7,8
PDSA - 40 L4	25/700	40/2,6	4	3,2	578	588	471,5	201	102	170	145	3/8" NPT	13	G 1/2"	11
PDSA - 40 L8	25/700	40/2,6	8	6,3	578	588	471,5	201	102	290	265	3/8" NPT	13	G 1/2"	16,5
PDS - 120 - SE	20/700	122/4,8	9	7,5	702	617	326	269	253	220	-	3/8" NPT	-	G 1/2"	22,5

Series
PDSA DE

Two speed hand pump aluminium, for double acting cylinders



PRODUCT PAGE

For double acting cylinders

CUSTOM PUMPS ON REQUEST



- High pressure hand pumps manufactured in light alloy of aeronautical grade aluminum to minimize the weight.
- Double stage version for double acting cylinders, with first stage 40 cc flow rate for rapid approach and 3 cc at the second stage. For maximum speed during operations.
- Pressure relief valve integrated in the pump body for maximum operator safety.
- High performance, low weight and excellent ergonomics.
- Integrated pressure gauge connection for direct assembly of measuring instrument.
- Oil filler cap with integrated breather. Tough pins with trough-holes for attachment to machinery or structures.
- Surface treatments to guarantee total reliability in the most difficult environments and maximum duration

PDSA DE

700 bar
40 - 3 cm³ oil flow
1,8 - 9 l capacity

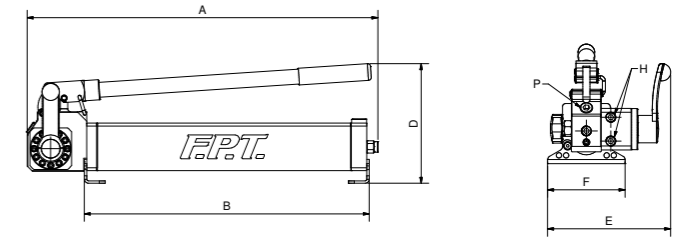

PDSA-40-DE

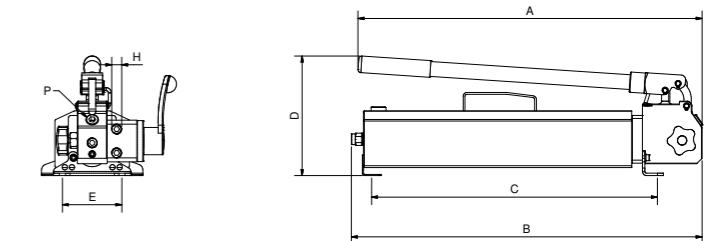
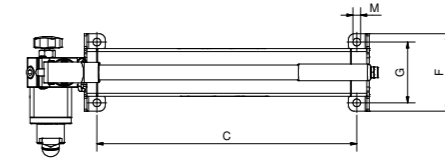

PDSA-40-DE L4/L8

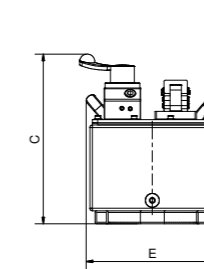
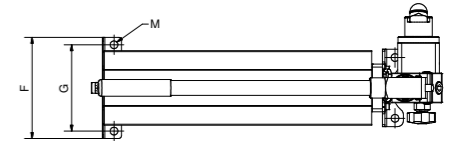

PDS-120-DE

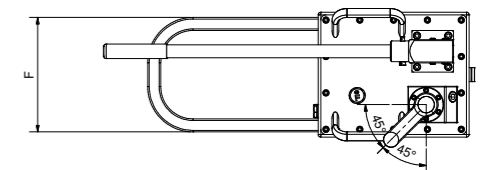
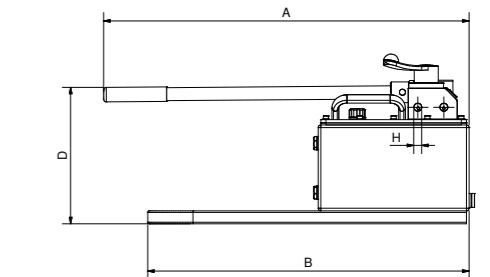

MODEL	PRESSURE	OIL FLOW	RESERVOIR	USABLE	DIMENSIONS (mm)										WEIGHT
	1 ST /2 ND STAGE	1 ST /2 ND STAGE	CAPACITY	OIL	A	B	C	D	E	F	G	H	M	P	
PDSA-40-DE	25/700	40/3	1,8	1,6	590	477	435	200	207	130	102	3/8" NPT	13	G 1/2"	9
PDSA-40-DE L4	25/700	40/2,6	4	3,2	578	588	471,5	201	102	170	145	3/8" NPT	13	G 1/2"	12
PDSA-40-DE L8	25/700	40/2,6	8	6,3	578	588	471,5	201	102	290	265	3/8" NPT	13	G 1/2"	17,5
PDS-120-DE	20/700	122/4,8	9	7,5	702	617	326	269	253	220	-	3/8" NPT	-	G 1/2"	22,5

Series
PDSA PMS

Hand pumps for very high pressures: 1.600 - 3.000 - 4.000 bar, aluminium



PRODUCT PAGE

For very high pressure

CUSTOM PUMPS ON REQUEST



- High pressure hand pumps manufactured in light alloy of aeronautical grade aluminum to minimize the weight.
- Two-stage versions 1.600 bar and 3.000 bar with first stage 40 cc oilflow for rapid approach and second stage 0.5 and 1 cc. And 0.5 cc per stroke 4,000 bar single-stage version.
- Pump body integrated pressure relief valve for maximum operator safety.
- Very high pressure, high performance, reduced effort on the handle, excellent weight and ergonomics.
- Integrated pressure gauge connection for direct mounting of the measuring tool.
- Oil filler cap with integrated breather. Tough pins with trough-holes for attachment to machinery or structures.
- Surface treatments to guarantee total reliability in the most difficult environments and maximum duration.

PDSA PMS

1.600 - 3.000 - 4.000 bar
1,8 l capacity

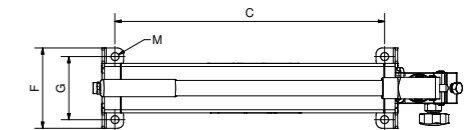
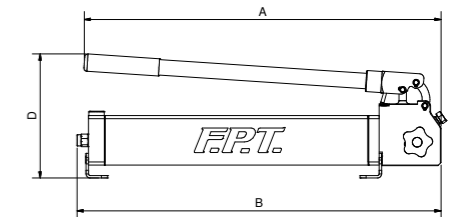
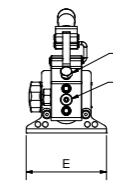

PDSA PMS 1600-1300-4000

PUMP	MODEL	PRESSURE	OIL FLOW	RESERVOIR	USABLE	DIMENSIONS (mm)										WEIGHT
		1 ST /2 ND STAGE	1 ST /2 ND STAGE	CAPACITY	OIL	A	B	C	D	E	F	G	H	M	P	
TWO-SPEED	PDSA-1600	25/1600	40/1	1,8	1,6	577	588,5	436	200	130	130	102	1/4" GAS	13	1/2" GAS	7,8
TWO-SPEED	PDSA-3000	16/3000	40/0,5	1,8	1,6	577	588,5	436	200	130	130	102	3/4"-16 UNF	13	9/16"-18 UNF	7,8
SINGLE-SPEED	PMS-4000	4000	0,5	1,8	1,6	577	588,5	436	200	130	130	102	9/16"-18 UNF	13	9/16"-18 UNF	7,8

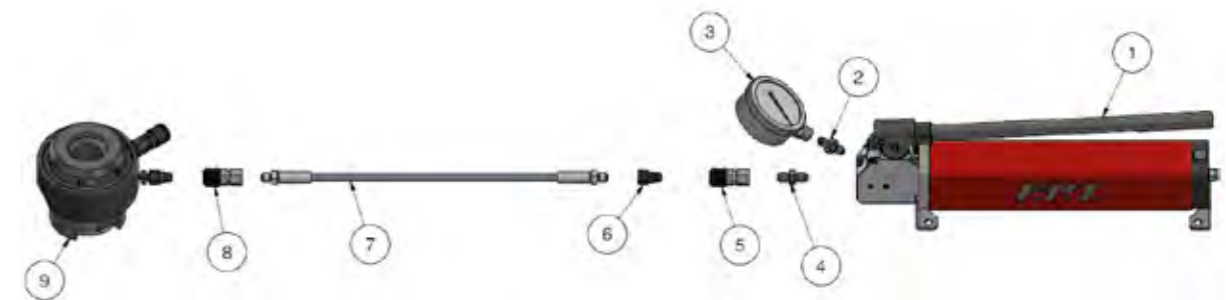

Configuration No.1 – Quick coupler on pump
Configuration No.2 – Flex hose directly assembled on the pump

	1500 Bar - Config.1	1500 Bar - Config.2	1600 Bar - Config.1	1600 Bar - Config.2	2500 Bar - Config.1	2500 Bar - Config.2	3000 Bar - Config.1	3000 Bar - Config.2	4000 Bar - Config.1	4000 Bar - Config.2
ITEM	CODE	CODE	CODE	CODE	CODE	CODE	CODE	CODE	CODE	CODE
1	01PDSA1600	01PDSA1600	01PDSA1600	01PDSA1600	01PDSA3000	01PDSA3000	01PDSA3000	01PDSA3000	01PMS4000	01PMS4000
2	-	-	-	-	0922225016	0922225016	0922225016	0922225016	0922225016	0922225016
3	01MD200G	01MD200G	01MD200G	01MD200G	01MD300G	01MD300G	01MD300G	01MD300G	01MD400G	01MD400G
4	0925613265	-	0925613265	-	09299199501611	0929112241	0922225257	0922225482	0922225016	-
5	07GR15F	-	07GR20F	-	07GR25F	-	07GR30F	-	07GR40F-M16	-
6	07GR15M	-	07GR20M	-	07GR25M	-	07GR30M	-	07GR40M-M16	-
7	01TFR#/1800	01TFR#/1800	01TFR#/1800	01TFR#/1800	01TFR#/2500	01TFR#/2500	01TFR#/3000M16D	01TFR#/3000M16G	01TFR#/4000M16D	01TFR#/4000M16H
8	07GR15F	07GR15F	07GR20F	07GR20F	07GR25F	07GR25F	07GR30F	07GR30F	07GR40F-M16	07GR40F-M16
9	Utilization	Utilization	Utilization	Utilization	Utilization	Utilization	Utilization	Utilization	Utilization	Utilization

insert length of the hose expressed in meters.



F.P.T. / HYDRAULIC HAND PUMPS

Custom made hydraulic hand pumps

FPT production is able to satisfy particular needs not only in the choice of construction materials, but also in the type of fluid to be pumped. On request we can build non magnetic steel hand pumps for nuclear uses or for installation on military vehicles. Hand pumps that can be used with water, various types of phosphoric esters, naphtha and other hydrocarbons.

The operating pressure can reach up to 4.000 bar. The manual pumps can be made in single stage or double stage for greater speed during the phases of approaching the load. With reduced capacity tanks to be more compact or up to 8 liters to manage more cylinders contemporary.

F.P.T. / HYDRAULIC POWER UNIT & SYNCHRONOUS LIFTING SYSTEM



03/

INDEX

HYDRAULIC POWER UNITS

	Motor	Standard oil tank capacity	Series		PAGE
Portable hydraulic minipumps	Single-phase electric	2,1	FPT-MPU		80
HPU, Hydraulic pumps, electric and pneumatic	Single-phase electric Three-phase electric Pneumatic	10	FPT		82
Gasoline driven hydraulic pumps	Gasoline	10	FPT-MS		84
Cordless battery hydraulic pumps	Battery	1 and 5	FPT BATT		92
Pneumohydraulic pumps	Pneumohydraulic	from 2,5 to 10	PP-700 PP-1000		94
	Pneumatic	from 5 to 10	PP		96
Pump for tests and geotechnics	Electric	from 20 to 40	FPT GEO		98
Hydraulic pumps with independent outlets for synchronized lifting	Electric	from 10 to 150	FPT SPLIT-FLOW		100
Synchronus lifting systems	Electric	from 20 to 150	FPT SYNCHRO		102

F.P.T. / HYDRAULIC POWER UNIT & SYNCHRONOUS LIFTING SYSTEM

POWER UNIT'S PART CODE

F.P.T. hydraulic power units are designed and produced to adapt to various customers' needs. They are available in 4 different engine configurations: three-phase or single-phase electric motor, with gasoline engine and pneumatic motor. Pressure range available from 700 bar to 4,000 bar. The power units are equipped with pumps for different flow rates, either in the single-stage version or two-stage. They can mount a wide range of, manual, electric or pneumatic valves for single or double acting cylinders. In the standard configuration are available 10 liters tanks up to 60 liters ones and a very wide range of accessories.

TOTAL FLEXIBILITY IN THE CONFIGURATION

The FPT and FPT Split Flow series hydraulic pumps are designed to guarantee maximum flexibility in configurations. The customer can easily choose each single component of the power unit according to his needs and add or replace parts or accessories in a short time afterwards. Motors, pumps, valves and accessories are all modular ones and interchangeable with each other.

CUSTOM HYDRAULIC UNITS ON CUSTOMER'S REQUEST

On demand:

- High flow rates for advanced performance
- Larger tanks
- Hydraulic circuits for specific needs
- Custom layouts
- Custom electric panels
- PLC automation and programming
- Extreme applications:



offshore | arctic environments | desert environments | aggressive environments.

PUMP		MOTOR		OILTANK CAPACITY	
FPT1	Double stage	MA	Air motor	10	Oiltank 10 litres
FPT2	Single stage	ME2	2 poles three-phase electric motor	20	Oiltank 20 litres
FPT5	Double stage	ME21	2 poles single-phase electric motor	40	Oiltank 40 litres
FPT9	Double stage	ME4	4 poles three-phase electric motor	60	Oiltank 60 litres
		ME41	4 poles single-phase electric motor		

VALVES					
VM32	manual valve for single acting cylinders with by-pass - 3/2 handle	VE43DRP	solenoid valve for double acting cylinders - with pilot operated check valve		
VM33	manual valve for single acting cylinders - 3/3	VE43OC	solenoid valve for oil return cylinders - with overcenter		
VM33RP	manual valve for single acting cylinders - 3/3 with pilot operated check-valve	VE43DOC	solenoid valve double acting cylinders - with overcenter		
VM43	manual valve for oil return cylinders - 4/3	VP32	pneumatic valve for single acting cylinders - 3/2		
VM43D	manual valve for double acting cylinders - 4/3	VP32A	pneumatic valve for single acting cylinders - 3/2 fit for accessories		
VM43RP	manual valve for oil return cylinders - 4/3 with pilot operated check-valve	VP33	pneumatic valve for single acting cylinders - 3/3		
VM43DRP	manual valve for double acting cylinders - 4/3 with pilot operated check-valve	VP33RP	pneumatic valve for single acting cylinders - 3/3 with pilot operated check-valve		
VM43OC	manual valve for oil return cylinder - 4/3 with overcenter	VP43	pneumatic valve for oil return cylinders - 4/3		
VM43DOC	manual valve for double acting cylinder - 4/3 with overcenter	VP43D	pneumatic valve for double acting cylinders - 4/3		
VE32	solenoid valve for single acting cylinders - 3/2	VP43RP	pneumatic valve for oil return cylinders - 4/3 with pilot operated check valve		
VE32A	solenoid valve for single acting cylinders - 3/2 fit for accessories	VP43DRP	pneumatic valve for double acting cylinders - 4/3 with pilot operated check-valve		
VE33	solenoid valve for single acting cylinders - 3/3	VP43OC	pneumatic valve for oil return cylinders - 4/3 with overcenter		
VE33RP	solenoid valve for single acting cylinders - 3/3 with pilot operated check-valve	VP43DOC	pneumatic valve for double acting cylinders - 4/3 with overcenter		
VE43	solenoid valve for oil return cylinders - 4/3	PT	PT baseplate with relief valve knob		
VE43D	solenoid valve for double acting cylinders - 4/3				
VE43RP	solenoid valve for oil return cylinders - 4/3 - with pilot operated check-valve				

ACCESSORIES					
DLOG	Datalogger	SC	Heat exchanger	SO	No oil
F	Filter on oil return	2U	2 outputs manifold	C1	Quick coupler
CP	Remote foot control	4U	4 outputs manifold	C2	Quick couplers
CD	Control pendant	G	Cage	C4	Quick couplers
CDP	Pneumatic control pendant	GR	Cage with pivoting wheels	C8	Quick couplers
RF	Unidirectional flow control valve	M100	Pressure gauge	FRL	FR+L group

Series **FPT-MPU** | Portable hydraulic mini pumps



PRODUCT PAGE

Light and portable

CUSTOM HYDRAULIC PUMPS ON REQUEST



- Hydraulic mini pump, extremely light and compact, suitable for all applications where easy handling is a priority.
- **Only 12 kg weight to operate in any environment.**
- Maximum working pressure 700 bar.
- Single-phase electric motor 230V-50Hz, power 0.55 kW.
- Radial piston pump, double stage, suitable for heavy-duty applications.
- Available for simple and double acting applications.
- Electrically operated valves.
- Remote control as standard on all models.
- 2.1 liters resin tank.
- Metal cage with ergonomic handle.
- Available with pressure gauge and handwheel pressure regulator.
- GR-6F female quick coupling as standard on the outlets.

FPT-MPU

700 bar
Double stage
1/0,5 l/min oil flow
2,1 l oiltank capacity

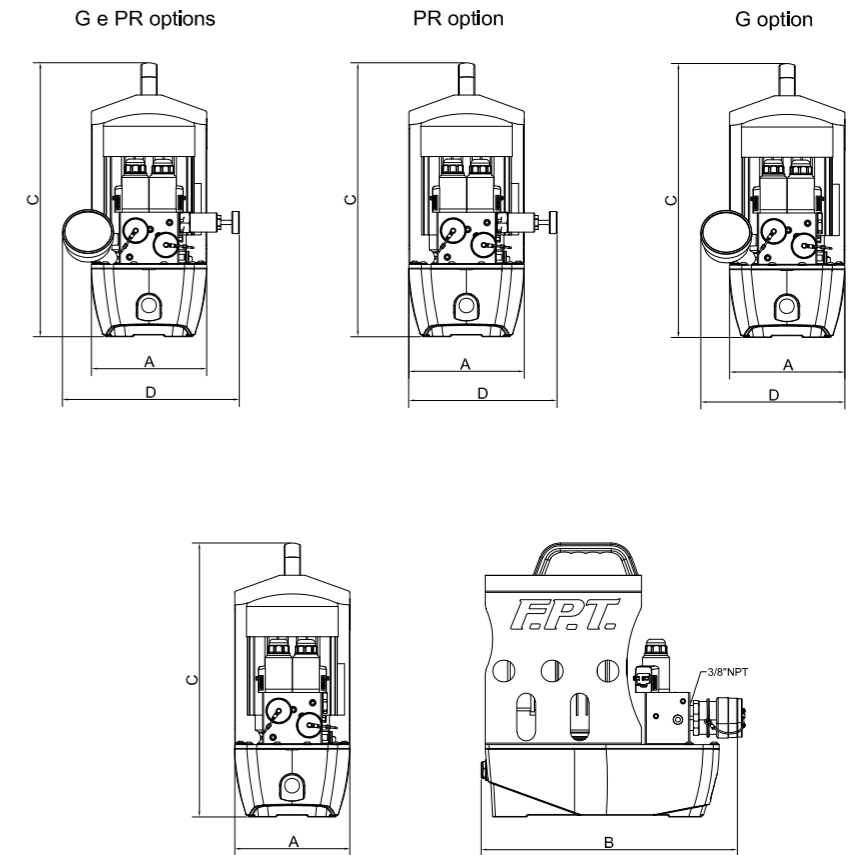

FPT-MPU

CODE	MODEL	PRESSURE	OIL FLOW	MOTOR	TENSION/	POWER/	TANK CAPACITY	DIMENSIONS mm				WEI-
		1°/2° STAGE	l/min		FREQUENCY	RPM		A	B	C	D	GHT
		bar				kW/rpm	litres					kg
31FPTMPU2SAS	FPT-MPU-2-SA-S	75/700	1/0,5	MONO PHASE ELECTRIC	230V-50Hz	0,55/2800	2,1	155	344	372	-	12
31FPTMPU2DAS	FPT-MPU-2-DA-S	75/700	1/0,5	MONO PHASE ELECTRIC	230V-50Hz	0,55/2800	2,1	155	344	372	-	12
31FPTMPU2SASG	FPT-MPU-2-SA-S-G	75/700	1/0,5	MONO PHASE ELECTRIC	230V-50Hz	0,55/2800	2,1	155	344	372	194	12
31FPTMPU2DASG	FPT-MPU-2-DA-S-G	75/700	1/0,5	MONO PHASE ELECTRIC	230V-50Hz	0,55/2800	2,1	155	344	372	194	12
31FPTMPU2SASPR	FPT-MPU-2-SA-S-PR	75/700	1/0,5	MONO PHASE ELECTRIC	230V-50Hz	0,55/2800	2,1	155	344	372	199	12
31FPTMPU2DASPR	FPT-MPU-2-DA-S-PR	75/700	1/0,5	MONO PHASE ELECTRIC	230V-50Hz	0,55/2800	2,1	155	344	372	199	12
31FPTMPU2SASGPR	FPT-MPU-2-SA-S-G-PR	75/700	1/0,5	MONO PHASE ELECTRIC	230V-50Hz	0,55/2800	2,1	155	344	372	238	12

OPTIONS

G	PRESSURE GAUGE
PR	PRESSURE REGULATOR
SA	FOR SINGLE ACTING CYLINDERS
DA	FOR DOUBLE ACTING CYLINDERS



PRODUCT PAGE

Maximum versatility and performance

CUSTOM HYDRAULIC PUMPS ON REQUEST



- The FPT model hydraulic pumps are the ideal solution for all industrial applications because of their extreme versatility and customization thanks to multiple configurations.
- Available with three-phase and single-phase electric motor or pneumatic.
- Possibility to install manual, electric or pneumatic, 3 or 4-way valves for single or double-acting cylinders and hydraulic equipment.
- With strong steel tank from 10 to 100 liters.
- Reduced maintenance. Designed to last.
- Wide range of accessories.
- Possibility to design and produce custom hydraulic pumps on request, with dedicated performance and features.
- Available models ATEX version. ▶ 

FPT

700 bar
Single – Double stage
0,9/0,45 - 7,5/0,9 l/min oil flow
From 10 to 60 l capacity

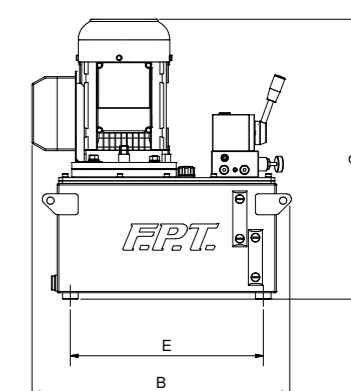
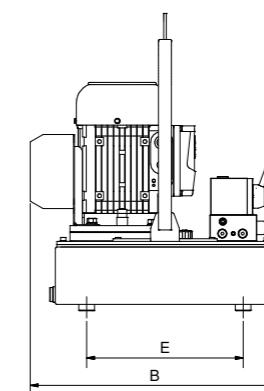
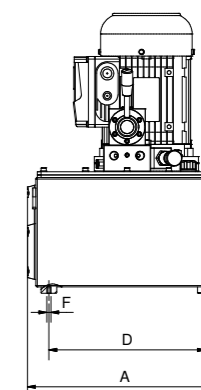
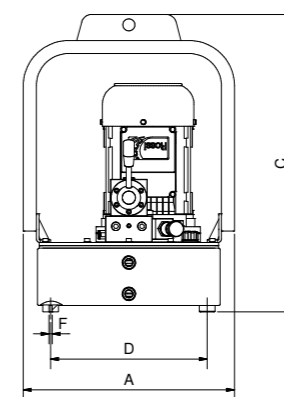

10L

20-40-60-100 L

MODEL	PRESSURE RATING 1st/2nd STAGE	OIL DISPLACEMENT 1st/2nd STAGE	MOTOR	KW RPM
	bar	l/min		
FPT 1 - ME4	100 / 700	0,9 / 0,45	THREE-PHASE 4 POLES	1,1 / 1450
FPT 1 - ME41		0,9 / 0,45	SINGLE-PHASE 4 POLES	1,1 / 1450
FPT 1 - ME2		1,8 / 0,9	THREE-PHASE 2 POLES	2,2 / 2850
FPT 1 - ME21		1,8 / 0,9	SINGLE PHASE 2 POLES	2,2 / 2850
FPT 1 - MA		1,8 / 0,9	PNEUMATIC	2,6 / 3000
FPT 2 - ME4		700	0,9	THREE-PHASE 4 POLES
FPT 2 - ME41	0,9		SINGLE-PHASE 4 POLES	1,1 / 1450
FPT 2 - ME2	1,8		THREE-PHASE 2 POLES	2,2 / 2850
FPT 2 - ME21	1,8		SINGLE PHASE 2 POLES	2,2 / 2850
FPT 2 - MA	1,8		PNEUMATIC	2,6 / 3000
FPT 5 - ME4	70 / 700		2,5 / 0,9	THREE-PHASE 4 POLES
FPT 5 - ME41		2,5 / 0,9	SINGLE-PHASE 4 POLES	1,1 / 1450
FPT 5 - ME2		4,5 / 1,8	THREE-PHASE 2 POLES	2,2 / 2850
FPT 5 - ME21		4,5 / 1,8	SINGLE PHASE 2 POLES	2,2 / 2850
FPT 5 - MA		4,5 / 1,8	PNEUMATIC	2,6 / 3000
FPT 9 - ME4	70 / 700	3,5 / 0,45	THREE-PHASE 4 POLES	1,1 / 1450
FPT 9 - ME41		3,5 / 0,45	SINGLE-PHASE 4 POLES	1,1 / 1450
FPT 9 - ME2		7,5 / 0,9	THREE-PHASE 2 POLES	2,2 / 2850
FPT 9 - ME21		7,5 / 0,9	SINGLE PHASE 2 POLES	2,2 / 2850
FPT 9 - MA		7,5 / 0,9	PNEUMATIC	2,6 / 3000

MOTOR	OILTANK CAPACITY	DIMENSIONS (mm)						WEIGHT kg
		A	B	C	D	E	F	
Electric ME	10	405	480	580	300	300	M8	36
	20	380	500	540	300	370	M8	49
	40	610	490	540	500	370	M8	69
	60	860	490	540	750	370	M8	91
	100	935	580	610	670	470	M10	152
Pneumatic MA	10	405	450	580	300	300	M8	33
	20	380	480	440	300	370	M8	46
	40	610	450	440	500	370	M8	56
	60	860	490	440	750	370	M8	87
	100	935	580	510	670	470	M10	148

Pneumatic and Electric pump's dimensions – NO CAGE

MOTOR	OILTANK CAPACITY	DIMENSIONS (mm)		
		A	B	C
Electric and Pneumatic ME - MA	10	470	570	570
	20	470	620	620
	40	750	540	620
	60	1000	540	620
	100	1000	700	755

Pneumatic and Electric pump's dimensions – WITH CAGE

Series **FPT-MS** | Gasoline driven hydraulic pumps



PRODUCT PAGE

Always operative

CUSTOM HYDRAULIC PUMPS ON REQUEST



- The FPT-MS series power units are the ideal solution for all applications where it is not possible to connect electric or air supply.
- Equipped with 4-stroke petrol engine.
- Possibility to install manual, electric or pneumatic, 3 or 4-way valves for single or double-acting cylinders and hydraulic equipment.
- With strong steel tank from 10 to 100 liters.
- The whole series is equipped with a protective cage that simplifies transport and lifting and protects the hydraulic pump on construction sites.
- Wide range of accessories, supplied without quick couplers.
- Possibility to design and produce custom hydraulic pumps on request, with dedicated performance and features.

FPT-MS

700 bar
Single – double stage
1,8/0,9 - 7,5/0,9 l/min oil flow
10 to 25 l oiltank

FPT-MS

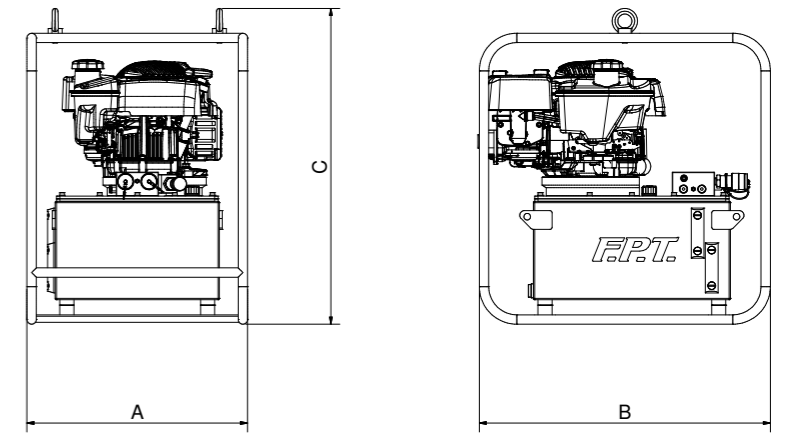

MODEL	PRESSURE RATING 1st/2nd STAGE	OIL DISPLACEMENT 1st/2nd STAGE	MOTOR
	bar	l/min	
FPT1-MS	100 / 700	1,8 / 0,9	4 STROKE PETROL ENGINE
FPT2-MS	700	1,8	4 STROKE PETROL ENGINE
FPT5-MS	70 / 700	4,5 / 1,8	4 STROKE PETROL ENGINE
FPT9-MS	70 / 700	7,5 / 0,9	4 STROKE PETROL ENGINE

MOTOR	OILTANK CAPACITY	DIMENSIONS (mm)			WEIGHT kg
		A	B	C	
4 STROKE PETROL ENGINE	10	470	600	625	39,8
	20	470	620	675	53
	40	750	555	675	65
	60	1000	555	675	97,5
	100	1000	700	755	174,5

Pneumatic and Electric pump's dimensions – WITH CAGE

Valves for hydraulic pumps

MODEL	DRIVE	HYDRAULIC DIAGRAM	DESCRIPTION
PT	Manual		P-T Block (with pressure relief knob)
VM32	Manual		Manual valve for single acting cylinders (bypass knob) 3 way / 2 position
VM33	Manual		Manual valve for single acting cylinders 3 way / 3 position
VM43/VM43D	Manual		Manual valve for oil return cylinders 4 way / 3 position
VE32	Electric		Solenoid valve for single acting cylinders 3 way / 2 position
VE32A	Electric		Solenoid valve for single acting cylinders 3 way / 2 position for accessories

MODEL	DESCRIPTION	HYDRAULIC DIAGRAM	ASSEMBLE ON	DESCRIPTION
RP	Pilot operated check valve		VE43/VE43D – VM43/VM43D – VP43/VP43D – VM33	Dual Pilot Operated Check Valve consists of two checkers (both on A and on B) which ensure perfect load holding. Example: With a non pilot operated manual valve when switching from position A to the central hold position, a small pressure drop occurs due to the geometry of the valve: it is a very small leakage but in some cases it is not acceptable. The check valve helps to overcome this problem. It is required in split-flow pumps when no overcenter is equipped.

MODEL	DRIVE	HYDRAULIC DIAGRAM	DESCRIPTION
VE33	Electric		Solenoid valve for single acting cylinders 3 way / 3 position
VE43/VE43D	Electric		Solenoid valve for oil return cylinders 4 way / 3 position
VP32	Pneumatic		Pneumatic valve for single acting cylinders 3 way / 2 position
VP32A	Pneumatic		Pneumatic valve for single acting cylinders 3 way / 2 position for tools
VP33	Pneumatic		Pneumatic valve for single acting cylinders 3 way / 3 position
VP43/VP43D	Pneumatic		Pneumatic valve for oil return cylinders 4 way / 3 position











MODEL	DESCRIPTION	HYDRAULIC DIAGRAM	ASSEMBLE ON	DESCRIPTION
OC	Over-center valve		VE43/VE43D – VM43/VM43D – VP43/VP43D	The over-center valve (or counter-balance) has the purpose of controlling the movement of a hydraulic cylinder subject to negative loads. This valve can only be mounted on double acting or oil return cylinders. Without this valve, the return of the cylinder (during the descent phase) would not be controlled, seriously endangering the operator and the hydraulic system integrity. The valve is pre-calibrated at factory settings and the operator must not make any type of adjustment. The most economical alternative to the over center valve is a unidirectional flow regulator (RFUA). In this case the operator must completely close it before making the lifting and then gradually open it during the descent phase, varying the opening of the valve until the ideal speed is reached. It is clear that this last system is certainly cheaper but it puts the operator at risk due to possible mistakes. Moreover, in combination with the split-flow pump, the over-center valve provides a very high precision even during the return phase.

Accessories for FPT series
hydraulic pumps

Series **FPT**

The FPT series hydraulic pumps are the ideal solution for all industrial applications because of their maximum versatility and customization thanks to the multiple configurations and the many standard accessories with which they can be equipped.

PICTURE	CODE	NAME	DESCRIPTION
	DLOG	Data-logger	Device capable of recording time / pressure values for subsequent analysis. Data that can be imported into Excel via free FPT software.
	F	Oil filter on return	Recommended for harsh environments: it is important because it increases the life of hydraulic components.
	CP	Foot remote control	To switch on / off the motor and control the valve remotely, 5 meters long electric cable, foot control.
	CD	Remote control	To switch on / off the motor and control the valve remotely, 5 meters long electric cable.
	CDP	Pneumatic remote control	To switch on / off the motor and control the valve remotely, 5 meters long electric cable.
	RF	Unidirectional flow control valve	This valve allows the free flow of oil in one direction and intercepts it in the opposite direction when completely closed. When opened the flow is free in both directions.
	SC	Heat exchanger	This accessory reduces the heating of the oil, particularly suitable for heavy applications
	2U	2 outputs manifold	Manifold to use two cylinders, with integrated needle valves to control the flow of each line

PICTURE	CODE	NAME	DESCRIPTION
	4U	4 outputs manifold	Manifold to use four cylinders, with integrated needle valves to control the flow of each branch.
	G	Cage	Protection frame with wheels to facilitate the transport of the pump and protect it from accidental impacts.
	GR	Cage with wheels	Protection frame to facilitate the transport of the pump and protect it from accidental impacts.
	M100	Pressure gauge	Pressure gauge 0/1000 bar – Ø 100 mm – thread ½" GAS
	S0	No oil	Pump supplied with no oil
	C1	Quick coupler	No.1 Female coupler mod.GR6F – 3/8" NPT
	C2	Quick couplers	No.2 female couplers mod.GR6F – 3/8" NPT
	C4	Quick couplers	No.4 female couplers mod.GR6F – 3/8" NPT
	C8	Quick couplers	No.8 female couplers mod.GR6F – 3/8" NPT
	FRL	FR+L group	Compact group consisting of a filter to retain impurities from the pneumatic circuit, a regulator to allow adjustment of the pressurized air supply, lubricator to make the hydraulic pump work properly.



Configure your high pressure electric or air hydraulic pump.

Creating your own high pressure, 700 bar, electric or air hydraulic pump is extremely easy. FPT can make the model best suited to your applications. Choose the type of piston pump, the single phase or three phase electric motor, with 2 or 4 poles or pneumatic and the relative flow rate l / min.

Utilise different tank capacity, choose the type of valve that can have manual, pneumatic or electric actuation and the type of hydraulic cylinders that you want to operate. It is also available a wide range of accessories including remote control, return filter, one-way valve, quick couplings, cages, pressure gauges and manifolds.

F.P.T. / HYDRAULIC POWER UNIT

Series **FPT BATT** | Cordless battery hydraulic pumps



PRODUCT PAGE

Super light and portable

CUSTOM HYDRAULIC PUMPS ON REQUEST



- Battery powered pump for operating single acting cylinders and tools.
- Cordless Battery Hydraulic Pumps with double stage configuration to maximize efficiency during operations.
- Battery powered: light, portable and equipped with shoulder strap for maximum Handling.
- Start button is located on the handle for easy use.
- The battery is lithium ion. Battery and battery charger are accessories that can be ordered separately.
- The optimal temperature range is 15 ° C ÷ 40 ° C. The oil to be used is ISO VG-10 mineral hydraulic.

FPT BATT

700 bar
Double stage
Battery powered
1 and 5 l oiltank

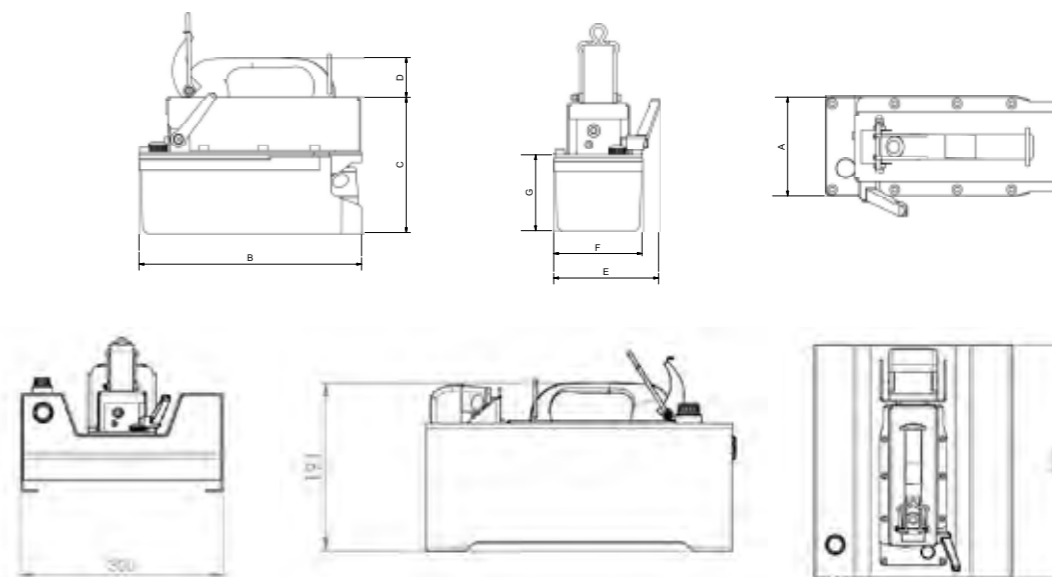

FPT BATT

CORDLESS BATTERY HYDRAULIC PUMPS SERIES FPT-BATT

MODEL	DESCRIPTION	PRESSURE	FLOW	MOTOR	BATTERY	TANK CAPACITY	A	B	C	D	E	F	G	OIL OUTLET	WEIGHT
		1°- 2° STAGE	1°- 2° STAGE				(mm)	(mm)	(mm)	(mm)	(mm)	(mm)	(mm)		
31FPT-BATT1.0SE	Cordless Battery pump including battery and battery charger	20 / 700	0,7 / 0,06	14,4 V - 199 W	14,4 V - 4 Ah	1	102	292	168	43	122	102	108	3/8" NPT	5
31FPT-BATT5.0SE		20 / 700	0,7 / 0,06			5	see drawing						25		

PRODUCTS

MODEL	DESCRIPTION	TANK CAPACITY
		liters
31FPTBATT1.0SE	Cordless Battery pump including battery and battery charger	1
31FPTBATT5.0SE		5
31FPTBATT1.0SEN	Cordless Battery pump without battery and battery charger	1
31FPTBATT5.0SEN		5
31CARICBATT14V	Battery charger for 14,4 V lithium battery	/
31BATT14.4-4.0	14,4 V – 4,0 Ah lithium battery	/



Series **PP-700/1.000** | Pneumohydraulic pumps 700 bar – 1.000 bar



PRODUCT PAGE

Easy and cheap

CUSTOM HYDRAULIC PUMPS ON REQUEST



- The control units PP700 and PP1000 are characterized by very compact dimensions.
- Maximum pressure 700 or 1000 bar.
- Made of high-strength technopolymers result light and transportable.
- 5 and 10 liter tanks available.
- Easy to operate by foot or by hand.
- To be connected to the compressed air line and at an operating pressure of 6 to 8 bar.
- Available models with single or double effect with 3 or 4 way directional valves.
- For maximum flexibility, available push-button panel for remote control and a wide range of accessories.

PP-700 / PP-1.000

700 - 1000 bar
Single stage
2,5 to 10 l reservoir

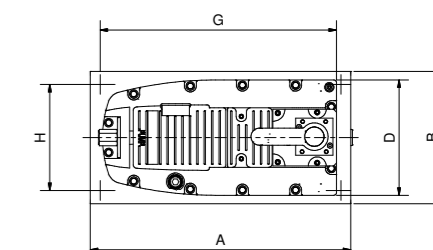
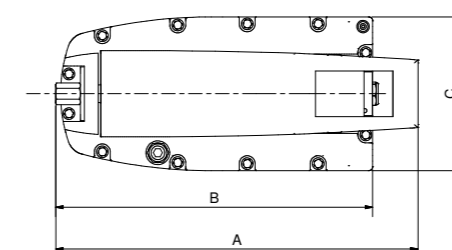
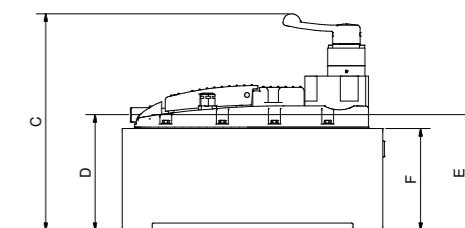
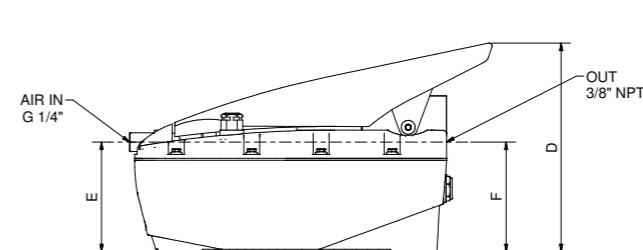

PP-700

PP-700TDEL5

MODEL	PRESSURE	OIL DISPLACEMENT l/min	OILTANK CAPACITY litres	USABLE OIL litres	AIR INLET PRESSURE bar	DIMENSIONS (mm)								WEIGHT kg	
	bar					A	B	C	D	E	F	G	H		L
PP 250 T	250	0,8	2,5	2,1	2,8-8	365	320	155	209	109	127	-	-	-	6,3
PP 250 T L5		0,8	4	4	2,8-8	350	178	255	155	175	137	310	140	6	12,5
PP 250 T L10		0,8	8	8	2,8-8	430	220	280	180	200	162	390	185	6	21
PP 700 T	700	0,8	2,5	2,1	2,8-8	365	320	155	209	109	127	-	-	-	6,3
PP 700 T L5		0,8	4	4	2,8-8	350	178	255	155	175	137	310	140	6	12,5
PP 700 T L10		0,8	8	8	2,8-8	430	220	280	180	200	162	390	185	6	21
PP 700 T DE		0,8	2,5	2,1	2,8-8	365	320	155	209	129	127	-	-	-	6,3
PP 700 T DE L5		0,8	4	4	2,8-8	350	178	291	155	176,5	137	310	142,5	6	12,5
PP 700 T DE L10		0,8	8	8	2,8-8	430	220	301	180	201,5	162	390	184,5	6	21
PP 700 T RC		0,8	2,5	2,1	2,8-8	365	320	155	209	109	127	-	-	-	6,3
PP 700 T RC L5		0,8	4	4	2,8-8	350	178	255	155	175	137	310	140	6	12,5
PP 1000 T		1000	0,8	2,5	2,1	2,8-8	365	320	155	209	109	127	-	-	-
PP 1000 T L5	0,8		4	4	2,8-8	350	178	255	155	175	137	310	140	6	12,5
PP 1000 T L10	0,8		8	8	2,8-8	430	220	280	180	200	162	390	185	6	21

Series **PP** | Pneumo hydraulic pumps
1.500 to 4.000 bar



PRODUCT PAGE

For very high pressure

CUSTOM HYDRAULIC PUMPS ON REQUEST



- PP series power units are the ideal solution for all very high pressure applications where it is necessary to connect to the compressed air line.
- Power units for tensioning bolts, burst tests, laboratory tests, scaling or keying of bearings, actuation of hydraulic bolt tensioners or hydraulic nuts and wherever high pressure is required.
- Standard versions with pressure 1500 bar - 2500 bar - 3000 bar and 4000 bar.
- Equipped with pressure relief valve for maximum operational safety.
- Handwheel pressure regulator valve.
- Pressure gauge, female quick coupler and standard pneumatic filter regulator assembly on all models.
- Models available with remote control pendant (CDP).
- Possibility to design and produce custom hydraulic power units on request, with dedicated performance and features.

PP

Single stage
5 to 10 l oiltank capacity
1500 to 3000 bar

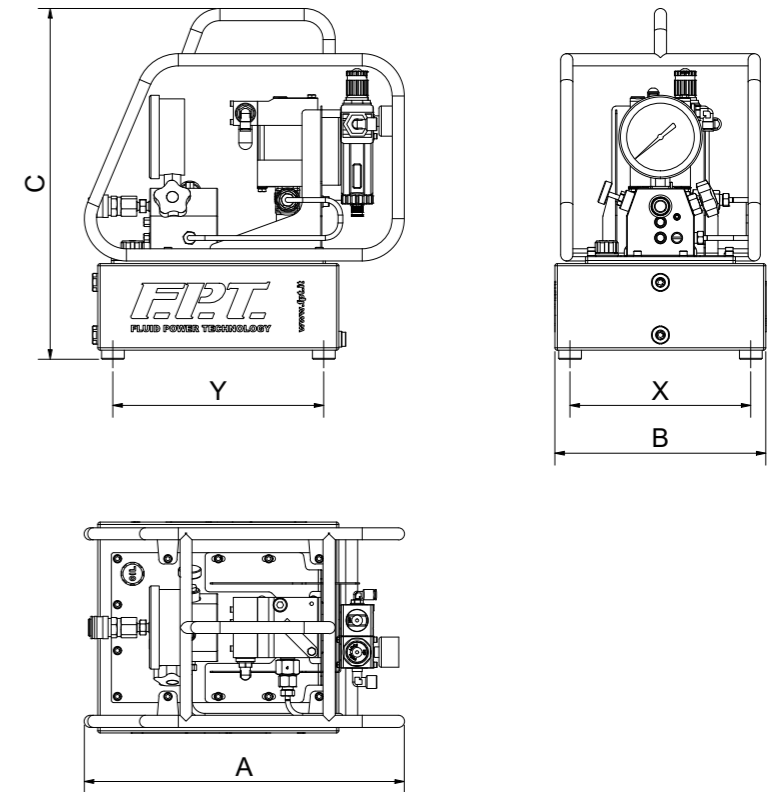

PP

MODEL	PRESSURE	MIN. NEEDED PRESSURE	AVG. AIR CONSUMPTION	MULTIPLICATION RATIO	OIL DISPLACEMENT NO LOAD	OIL DISPLACEMENT MAX PRESSURE	OILTANK CAPACITY	AIR PRESSURE RANGE	DIMENSIONS (mm)					FIXING HOLES	MASS (OIL INCLUDED)
									A	B	C	X	Y		
PP1500C05	1500	7	500	1:220	0,28	0,01 @ 7 bar	5	1 - 10 bar	425	265	466	165	250	nr.4 M8x12	19,5
PP1500C10	1500	7	500	1:220	0,28	0,01 @ 7 bar	10		425	280	466	240	280	nr.4 M8x12	25,5
PP1500C05/CDP	1500	7	500	1:220	0,28	0,01 @ 7 bar	5		425	265	466	165	250	nr.4 M8x12	21,0
PP1500C10/CDP	1500	7	500	1:220	0,28	0,01 @ 7 bar	10		425	280	466	240	280	nr.4 M8x12	27,0
PP2500C05	2500	6	600	1:440	0,21	0,03 @ 6 bar	5		425	265	466	165	250	nr.4 M8x12	20,5
PP2500C10	2500	6	600	1:440	0,21	0,03 @ 6 bar	10		425	280	466	240	280	nr.4 M8x12	26,5
PP2500C05/CDP	2500	6	600	1:440	0,21	0,03 @ 6 bar	5		425	265	466	165	250	nr.4 M8x12	22,0
PP2500C10/CDP	2500	6	600	1:440	0,21	0,03 @ 6 bar	10		425	280	466	240	280	nr.4 M8x12	27,5
PP3000C05	3000	8	700	1:440	0,21	0,06 @ 8 bar	5		425	265	466	165	250	nr.4 M8x12	20,5
PP3000C10	3000	8	700	1:440	0,21	0,06 @ 8 bar	10		425	280	466	240	280	nr.4 M8x12	26,5
PP3000C05/CDP	3000	8	700	1:440	0,21	0,06 @ 8 bar	5		425	265	466	165	250	nr.4 M8x12	22,0
PP3000C10/CDP	3000	8	700	1:440	0,21	0,06 @ 8 bar	10		425	280	466	240	280	nr.4 M8x12	27,5
PP4000C10	4000	7	800	1:660	0,19	0,05 @ 7 bar	10		425	280	475	240	280	nr.4 M8x12	26,5
PP4000C10/CDP	4000	7	800	1:660	0,19	0,05 @ 7 bar	10		425	280	475	240	280	nr.4 M8x12	29,5

Series **FPT GEO** | Pump for tests and geotechnics



PRODUCT PAGE

For automatic pressure recovery

CUSTOM HYDRAULIC PUMPS ON REQUEST



- The most reliable method for determining bearing capacity of a pole is to subject it to a load test. This means planting the pile to the project depth and applying a succession of loads to it.
- FPT GEO series power units perfectly accomplish this task ensuring the maintenance of the pre-set load.
- With the practical microprocessor display it is possible to set the desired pressure. The pump will maintain this value, restoring it in case of leaks or yielding.
- Available with three-phase or single-phase electric motor.
- Protective cage with integrated electrical panel and eyelets for lifting, 20 and 40 liters tank capacity.
- Possibility to design and produce custom hydraulic pumps on request, with dedicated performance and features.
- For years F.P.T. cares of the environment and its protection. It has in fact various products suitable for use with water or fluids 100% biodegradable.



FPT GEO

700 bar
Double stage
2,5 - 0,9 l/min oil flow
10 to 60 l oiltank capacity

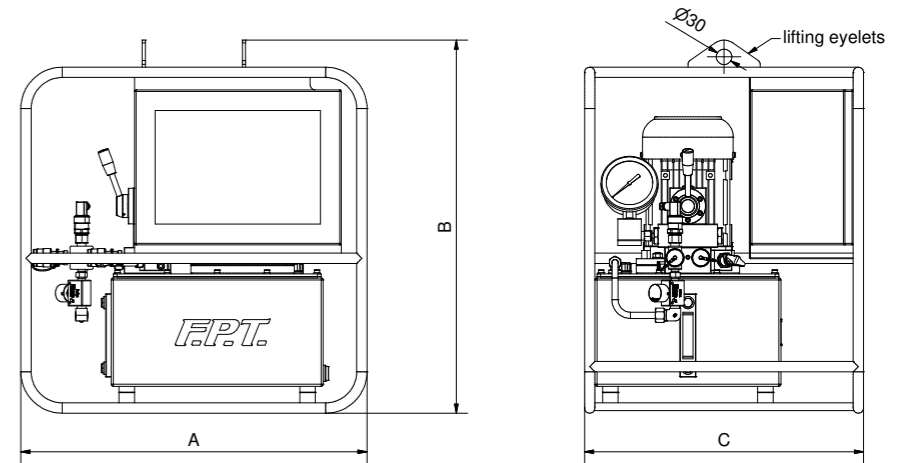

FPT GEO

MODEL	PRESSURE	OIL	MOTOR	VOLTAGE/ FREQUENCY	KW/RPM	OILTANK CAPACITY	DIMENSIONS (mm)			WEIGHT
	1st/2nd STAGE	DISPLACEMENT		V/Hz						
FPT5-ME4-20-GEO	100/700	2,5/0,9	THREE PHASE ELECTRIC	400V-50Hz	1,1/1440	20	670	772	540	75
FPT5-ME41-20-GEO	100/700	2,5/0,9	MONO PHASE ELECTRIC	230V-50Hz	1,1/1440					75
FPT5-ME4-40-GEO	100/700	2,5/0,9	THREE PHASE ELECTRIC	400V-50Hz	1,1/1440	40	670	772	540	94
FPT5-ME41-40-GEO	100/700	2,5/0,9	MONO PHASE ELECTRIC	230V-50Hz	1,1/1440					94

**FPT – TECH Series
HYDRAULIC PUMPS FOR TESTS
AND PRESSING TESTS**



More and more customers need to have a technologically advanced product to perform pressure tests. F.P.T. realizes for this specific sector those power units suitable for operations with water or biodegradable fluids, able of perform pressure tests, record data and be remotely controlled.

Equipped with PLC and dedicated FPT software, they are the ideal tool for all testing and product validation and are completely customizable based on specific customer needs.



Series **FPT SPLIT FLOW** | Hydraulic pump with independent outlets



PRODUCT PAGE

For synchronous lifting

CUSTOM HYDRAULIC PUMPS ON REQUEST



- Split Flow power units allow to perform synchronous lifting and lowering operations of irregular and unbalanced loads.
- Can handle 2 - 4 - 6 and 8 single or double effect cylinders.
- Piston pump with independent outputs ideal for carrying on lifting operations where high accuracy load leveling is required.
- $\pm 3\%$ accuracy on the nominal stroke when lifting with single-acting cylinders and during lifting and lowering with double-acting cylinders.
- Available manual or electric valves with related control pendant and counter-balance valves for load control during descent.
- The split flow hydraulic pumps have tanks from 10 to 150 liters and allow to operate a wide range of medium and high tonnage cylinders. It finds its ideal use in large lifts, in infrastructural construction, heavy carpentry and in industry and in all sectors where there is a need to manage a load.

FPT SPLIT FLOW

700 bar
Single stage
0,4 - 0,9 l/min oil flow
10 to 60 l oiltank capacity

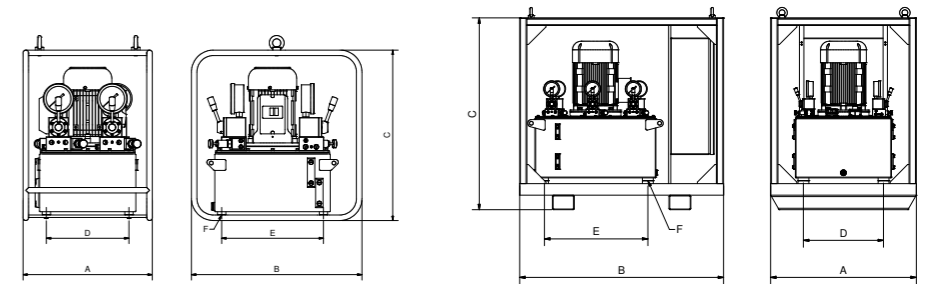

SPLIT FLOW

SPLIT FLOW-HF

FPT SPLIT FLOW-HF

700 bar
Single stage
1,3 - 2 l/min oil flow
150 l oiltank capacity

MODEL	OUTPUTS	MAX WORKING PRESSURE	OIL DISPLACEMENT PER OUTPUT	MOTOR	KW RPM
		bar	l/min		
FPT 2x0,9 - ME2	2	700	0,9	THREE-PHASE 2 POLES	2,2 / 2850
FPT 2x0,9 - ME21	2		0,9	SINGLE-PHASE 2 POLES	
FPT 4x0,4 - ME2	4		0,4	THREE-PHASE 2 POLES	
FPT 4x0,4 - ME21	4		0,4	SINGLE-PHASE 2 POLES	
FPT 4X2 - ME4-HF	4		2	THREE-PHASE 4 POLES	11 / 1450
FPT 6X1,3 - ME4-HF	6		1,3	THREE-PHASE 4 POLES	11 / 1450
FPT 8X1,3 - ME4-HF	8		1,3	THREE-PHASE 4 POLES	15 / 1450

OILTANK CAPACITY	DIMENSIONS (mm)			WEIGHT
	A	B	C	kg
10	870	600	600	51
20	870	600	600	64
40	935	580	740	91,8
60	1085	580	740	113,8
150	1000	1400	1320	438

OILTANK CAPACITY	DIMENSIONS (mm)						WEIGHT
	A	B	C	D	E	F	Kg
10	405	480	580	300	300	M8	36
20	380	500	540	300	370	M8	49
40	610	490	540	500	370	M8	69
60	860	490	540	750	370	M8	91

Split flow pump's dimensions - WITHOUT PROTECTION CAGE | Split flow pump's weight are consider - WITHOUT OIL

PICTURE	CODE	NAME	DESCRIPTION
	CD	Remote control	To switch on / off the motor and control the valve remotely, 5 meters long electric cable.
	RF	Unidirectional flow control valve	This valve allows the free flow of oil in one direction and intercepts it in the opposite direction when completely closed. When opened the flow is free in both directions.
	G	Cage	Protection frame with wheels to facilitate the transport of the pump and protect it from accidental impacts.
	GR	Cage with wheels	Protection frame to facilitate the transport of the pump and protect it from accidental impacts.
	M100	Pressure gauge	Pressure gauge 0/1000 bar - Ø 100 mm - thread 1/2" GAS
	SO	No oil	Pump supplied with no oil

Series
F.P.T. SYNCHRO | Synchronous lifting system



PRODUCT
PAGE

For fully automatic and safe operations in handling a load.

Lifting with a precision of 1 mm

F.P.T. manufactures integrated lifting systems controlled by PLC. The F.P.T. SYNCHRO allows the operator to carry out each step of the lifting and descending process synchronously through integrated management of the hydraulic and control part. Unbalanced loads are kept levelled during the up or down phases, with leveling accuracy equal to 1 mm.

The system was developed to adapt to customer lifting needs and can be totally customizable with a series of optional. It is the ideal tool for operations of lifting or weighing that need accurate control's systems functions. The F.P.T. system is user friendly, safe and modular.

Typical application of synchronous lifting from 4 to 48 points:

Thanks to stroke and pressure transducers feedbacks,

the system allows lifting and lowering in a synchronous way with the precision of 1 mm, reducing the risk of excessive stress due to unbalanced distribution of the loads between the lifting points.

The operator can set on the PC screen the parameters of the operation to be performed, decide the number of cylinders to use, the stroke, the accuracy and the speed to operate. All data during operations are always monitored by the system increasing productivity and safety during operations. All data are stored and can be downloaded later.



Basic system composition:

- 700 bar hydraulic pump with radial piston pump, three-phase motor inverter controlled
- laptop or touch screen panel
- wire transducers for stroke control
- armored cables complete with industrial connectors

For use with single or double acting hydraulic cylinders.

Controls - Operator panel:

- Monitoring from 4 to 48 lifting points.
- Controlled movement for lifting / lowering.
- Possibility to select the cylinders to be operated.
- 2 modes available: automatic or manual.
- Possibility to set the maximum lag permitted.
- Accuracy on synchronism of 1 mm.
- Load and stroke alarm display for maximum safety during operations.
- Display of the maximum relative error between various cylinders.
- Download and storage of data related to lifting.

Speed optimization

The system is able to optimize the speed of load lifting / lowering regardless of number and size of cylinders maintaining the error within the set limit. The operator panel also allows the approach of the cylinders to the structure/formwork to lift, thus allowing a considerable saving of time.

The information displayed for each cylinder are:

- relative and absolute position
- pressure
- force
- direction (upward / downward)
- information relating to errors



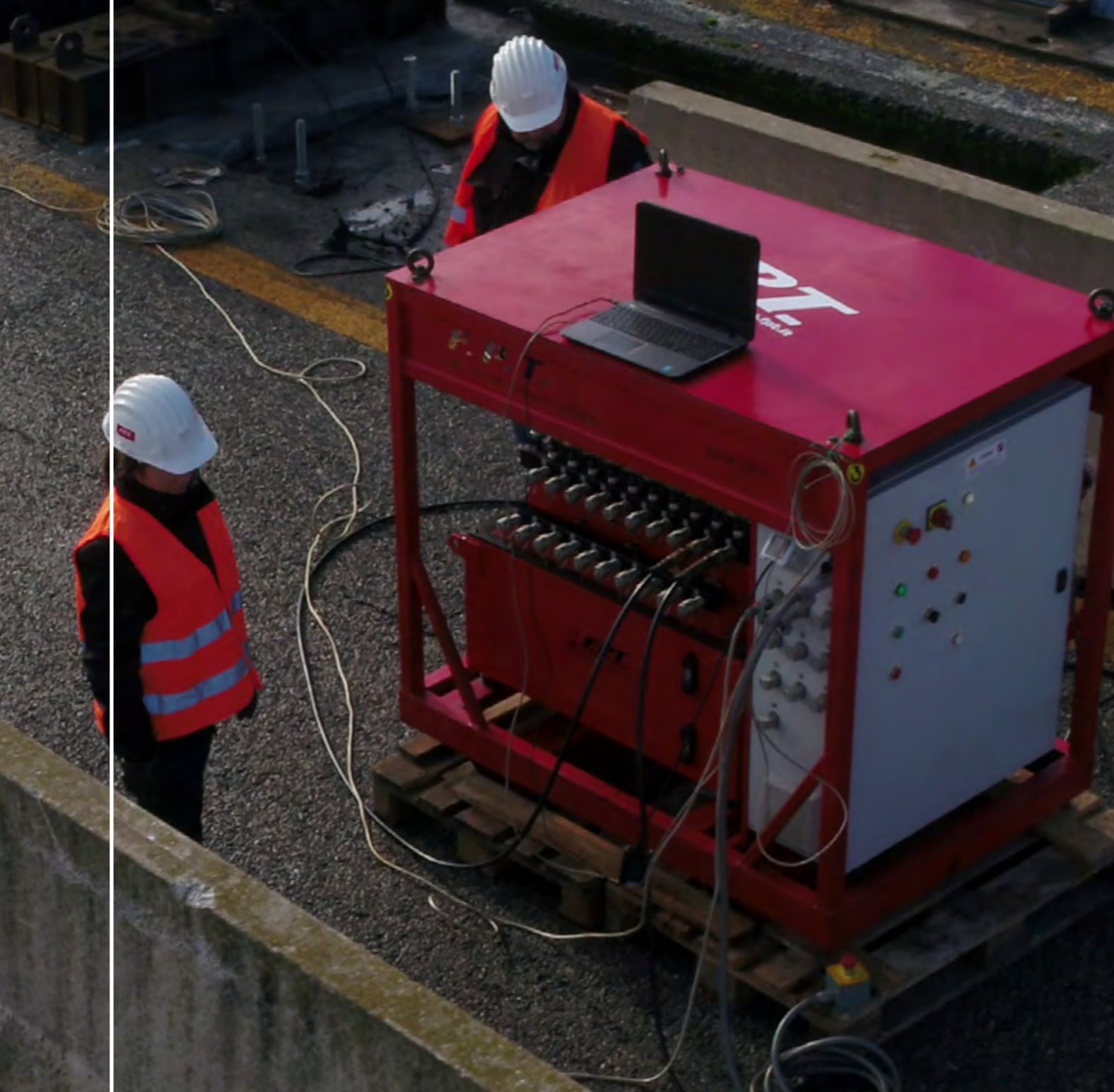

Optionals available:

- Rotation on synchro
- Center of gravity - COG

Typical synchronized applications:

- Handling of heavy structures.
- Maintenance, launch or construction of bridges
- Load transfer operations
- Installation or maintenance of heavy systems
- Positioning of offshore platforms
- Weighing operations



The ideal system for heavy and critical lifting jobs and for weighing operations – where are needed delicate control operations without manual control. Unbalanced loads are automatically kept leveled during the lifting or the lowering phases, with an accuracy of 1 mm.

- Easy and intuitive interface
- All operations can be performed automatically from the PC - no manual operation
- Siemens PLC
- Errors and alarms in case of anomalies or out-of-parameter operations

F.P.T. / VALVES, HOSES AND AUXILIARY COMPONENTS

FOR AN ALWAYS RELIABLE CONTROL

INDEX

VALVES, HOSES AND AUXILIARY COMPONENTS



04/

Series

Complementary valves for flow rate
and pressure control

V



PAGE
108

Pressure gauges

MD



110

Accessories for pressure gauges

VM
PM



111

Flex hoses

TFG
TFR



112

Quick couplers

GR



114

Manifold fittings, oil

MR
MA
ML





116

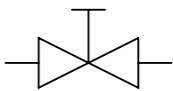
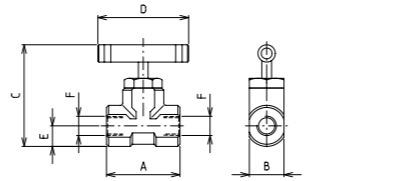

PRODUCT PAGE

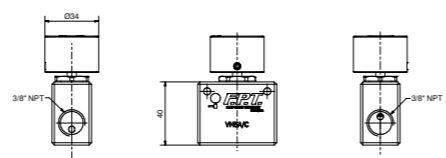
	TYPE OF VALVE	HYDRAULIC DIAGRAM	DESCRIPTION	TECHNICAL DRAWING		
	NEEDLE VALVE 700 BAR		Inline needle valve used to exclude or hold parts of the hydraulic circuit under pressure (female-female).			
MODEL	A	B	C	D	E	F
VM - 5A	68	32	94	84	19	3/8" NPT

	MODEL	NUMBER OF USES	MAX WORKING PRESSURE (bar)	DIMENSIONS (mm)
	VM5A/C	2	700	

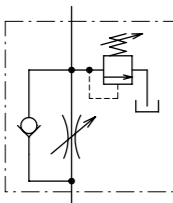
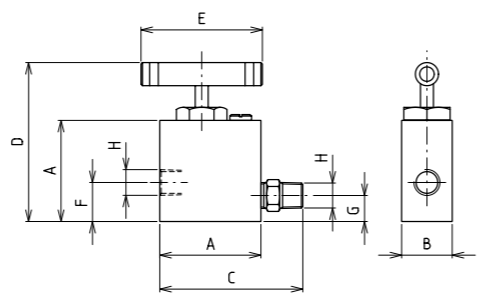
	TYPE OF VALVE	HYDRAULIC DIAGRAM	DESCRIPTION	TECHNICAL DRAWING				
	UNIDIRECTIONAL FLOW CONTROL VALVE 700 BAR		Unidirectional flow control valve, allows the lowering of the load in a controlled manner. The built-in relief valve protects the circuit against overpressure.					
MODEL	A	B	C	D	E	F	G	H
RFUA	70	35	100	110	84	27	18	3/8" NPT

Other models of 3-way valves also available

Dimensions (mm)

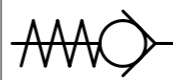
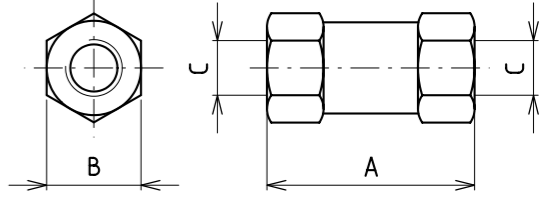
	TYPE OF VALVE	HYDRAULIC DIAGRAM	DESCRIPTION	TECHNICAL DRAWING
	VALVE OF RETURN 700 BAR		Inline unidirectional check valve. It blocks the flow in one direction while allowing it to move in the opposite direction.	
MODEL	A	B	C	
VR - A38	66	30	3/8" NPT	

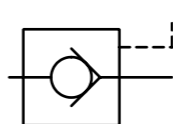
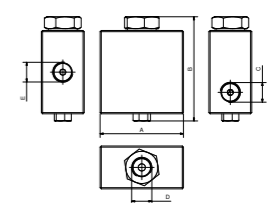
	TYPE OF VALVE	HYDRAULIC DIAGRAM	DESCRIPTION	TECHNICAL DRAWING	
	VRPLAC		Inline pilot-operate check valve: blocks the flow in one direction allowing it to move in the opposite direction. The circuit is unblocked thanks to a pilot pressure 4 times lower than the circuit pressure.		
MODEL	A	B	C	D	E
VRPLAC	70	87,5	3/8" NPT	3/8" NPT	3/8" NPT

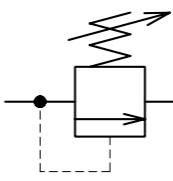
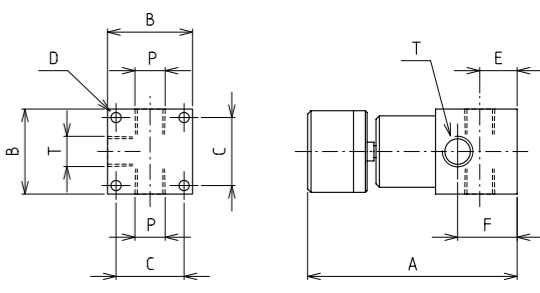
	TYPE OF VALVE	HYDRAULIC DIAGRAM	DESCRIPTION	TECHNICAL DRAWING				
	PRESSURE RELIEF VALVE 700 BAR		Pressure relief valve; the knob is used to regulate the pressure in the circuit. For inline mounting.					
MODEL	A	B	C	D	E	F	P	T
VMPL - A	125	50	40	5,5	22	35	3/8" NPT	3/8" NPT

Other models of 3-way valves also available

Dimensions (mm)



PRODUCT PAGE

- Excellent precision and readability, easy to assemble.
- Digital or dual pressure reading scale (bar - ton).

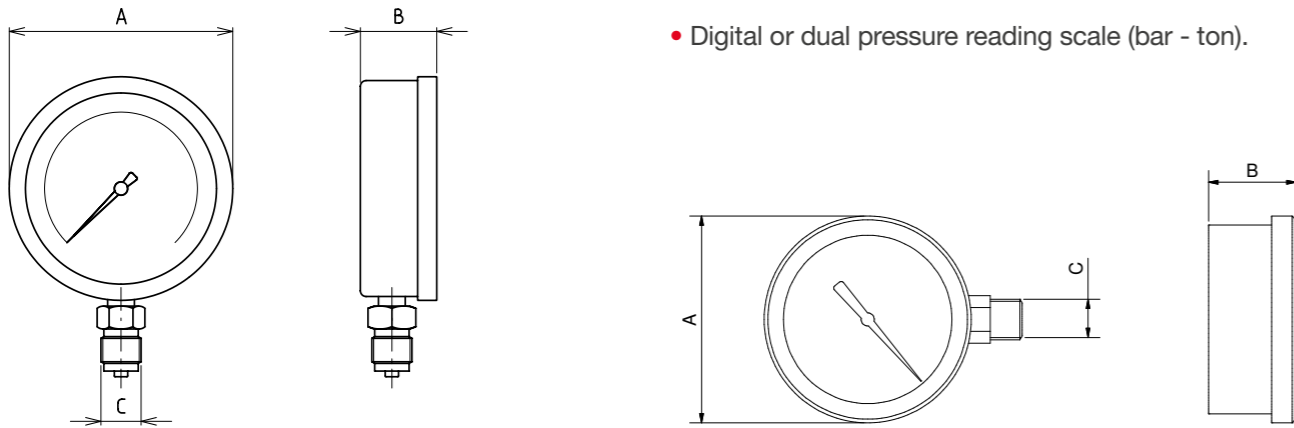

MD PRESSURE GAUGES

MD-60G/H3

MODEL	PRESSURE RANGE		PRECISION CLASS	Ø FACE mm	TYPE	DIMENSIONS (mm)		
	Bar	Psi				A	B	C
MD 60G/H3	0 - 1000	0 - 14000	1,6	60	IN GLYCERINE BATH	68	28	1/4" NPT
MD 60G	0 - 1000	0 - 14000	1,6	60	IN GLYCERINE BATH	68	28	1/4" NPT
MD 100G	0 - 1000	0 - 14000	1,0	100	IN GLYCERINE BATH	110	36	G 1/2"
MD 160G	0 - 1600	0 - 23000	1,0	100	IN GLYCERINE BATH	110	47	G 1/2"
MD 200G	0 - 2000	0 - 30000	1,0	100	IN GLYCERINE BATH	110	50	G 1/2"
MD 300G	0 - 3000	0 - 45000	1,0	100	IN GLYCERINE BATH	110	50	M16x1,5 Female
MD 400G	0 - 4000	0 - 60000	1,0	100	IN GLYCERINE BATH	110	50	M16x1,5 Female

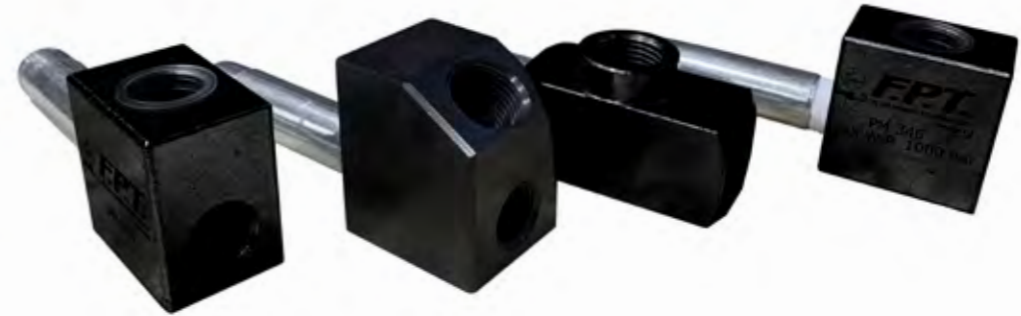

PRODUCT PAGE

Pressure gauge adaptors

The FPT system can be used to mount the pressure gauge directly on the pump head. The pressure gauge adaptors are required on pumps and valves when the pressure gauge is not directly installed.

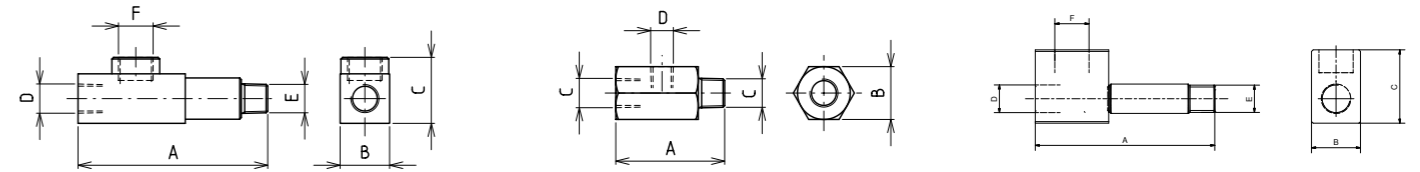

PM-351

PM-355 PM-356

PM-346 PM-348

MODEL	MODEL	DIMENSIONS (mm)					
		A	B	C	D	E	F
	PM - 346	115	30	45	3/8" NPT	3/8" NPT	G 1/2"
	PM - 348	111	35	50	3/8" NPT	3/8" NPT	G 1/2"
	PM - 351	115	30	40	3/8" NPT	1/4" NPT	G 1/2"
	PM - 355	68	27	1/4" NPT	1/4" NPT	-	-
	PM - 356	68	32	3/8" NPT	1/4" NPT	-	-

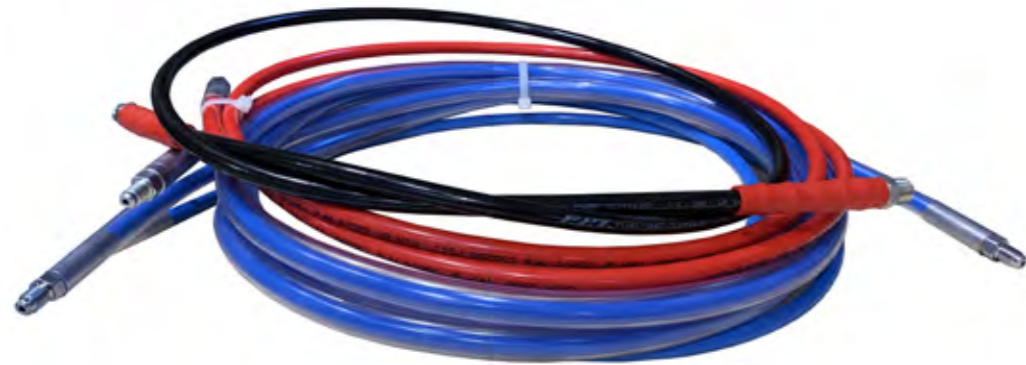

PRODUCT PAGE

High pressure hoses

CUSTOM FLEX HOSES ON REQUEST



The 1000 bar thermoplastic flex hoses standard 1/4 version with internal Ø 6.3 mm are suitable for demanding applications and have a safety factor of 2.8: 1. On request, also available hoses with custom sizes and fittings, flexible hoses with internal Ø of 9.7 mm for applications with high flow rates as well.

For very high pressure applications, thermoplastic hoses available in a range from 1.800 to 4.000 bar to cover all market needs.

FLEX HOSES

Max working pressure
1.000 to 4.000 bar

MAX W.P.	1000 BAR							
	TFR #		TFRR #		TFG #		TFGG #	
	END 1	END 2	END 1	END 2	END 1	END 2	END 1	END 2
0,6	3/8" NPT		1/4" NPT		3/8" NPT	GR-6M	GR-6M	
1								
2								
3								
4								
5								
6								
10								

MAX W.P.	1800 BAR		2500 BAR		3000 BAR		3000 BAR		4000 BAR		4000 BAR	
	TFR # / 1800		TFR # / 2500		TFR # / 3000-M16D		TFR # / 3000-M16G		TFR # / 4000-M16D		TFR # / 4000-M16H	
	END 1	END 2	END 1	END 2	END 1	END 2	END 1	END 2	END 1	END 2	END 1	END 2
1	1/4" GAS M - 120°		1/4" GAS M - 120°		M16x1,5	1/4" GAS F - 60°	M16x1,5	M16x1,5	1/4" HP	M16x1,5		
1,5												
2												
3												
4												
5												
6												

insert length of the hose expressed in meters





PRODUCT PAGE

For quick and safe connection of the hydraulic circuits

CUSTOM QUICK COUPLERS ON REQUEST



700 bar couplings available in high flow version. Female quick couplings are equipped with dust caps. For very high pressures, quick couplings are available up to 4,000 bar depending on specific needs.

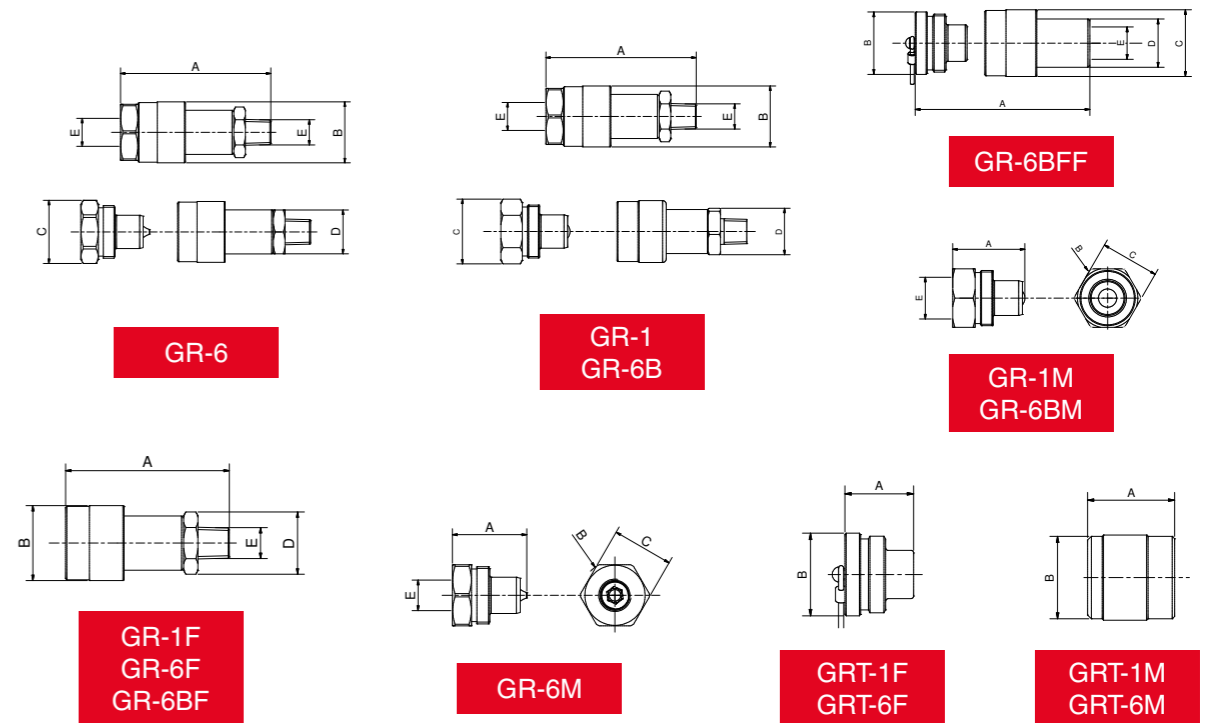

MODEL	Description				
	A	B	C	D	E
GR-1	78	30	CH27	CH22	1/4" NPT
GR-6	86	35	CH32	CH25	3/8" NPT
GR-6B	86	35	CH32	CH25	3/8" NPT
GR-1F	58	30	-	CH22	1/4" NPT
GR-6F	76	35	-	CH25	3/8" NPT
GR-6BF	76	35	-	CH25	3/8" NPT
GR-1M	37	30	CH27	-	1/4" NPT
GR-6M	39	36	CH32	-	3/8" NPT
GR-6BM	35,5	36	CH32	-	3/8" NPT
GRT-1M	28	30	-	-	-
GRT-6M	36	35,5	-	-	-
GRT-1F	20	28	-	-	-
GRT-6F	27	32,5	-	-	-

MAX WP	MODEL	Description	Connection
700 bar - high flow	GR-6F	Female coupler, male threaded, poppet valve	3/8" NPT Male
	GR-6M	Male coupler, female threaded, poppet valve	3/8" NPT Female
	GR-6	Complete quick coupler (GR-6F + GR-6M) and poppet valve	3/8" NPT Male
700 bar	GR-6BF	Female quick coupler, male threaded and ball valve	3/8" NPT Male
	GR-6BM	Male quick coupler, female threaded and ball valve	3/8" NPT Female
	GR-6BFF	Female quick coupler, female threaded and ball valve	3/8" NPT Female
	GR-6B	Complete quick coupler (GR-6F + GR-6M) and ball valve	3/8" NPT Male
	GRT-6M	Dust cap for GR-6M	-
	GR-1F	Female quick coupler, male threaded and ball valve	1/4" NPT Male
	GR-1M	Male quick coupler, female threaded and ball valve	1/4" NPT Female
	GR-1	Complete quick coupler (GR-1F + GR-1M) and ball valve	1/4" NPT
1500 bar	GR-15F	Female quick coupler, female threaded	1/4" G
	GR-15M	Male quick coupler, female threaded	
2500 bar	GR-25F	Female quick coupler, female threaded	M16x1,5
	GR-25M	Male quick coupler, female threaded	
3000 bar	GR-30F	Female quick coupler, female threaded	M16x1,5
	GR-30M	Male quick coupler, female threaded	
4000 bar	GR-40F-M16	Female quick coupler, female threaded	M16x1,5
	GR-40M-M16	Male quick coupler, female threaded	

Series
MR - MA - ML
MI - VM - MR

Manifolds - fittings and hydraulic oil up to 4.000 bar



PRODUCT PAGE

For quick and safe connection of the hydraulic circuits

CUSTOM VALVES ON REQUEST







- Used to connect multiple lines to one inlet.
- Built with radial or linear outlet. The linear models are supplied with a pressure gauge installation hole.
- Available in 11 standard models and in custom versions for high pressure jobs.
- From 700 to 4.000 bar

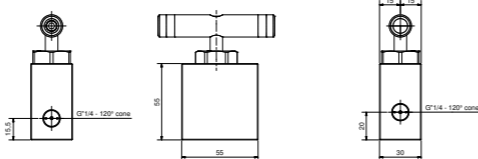

	MODEL	NUMBER OF USES	MAX WORKING PRESSURE (bar)	DIMENSIONS (mm)									
				A	B	C	D	E	F	G	H		
	MR - 3V	3	700	70	26	3/8" NPT							
	MR - 5V	5		70	26	3/8" NPT							
	MR - 11V	11		148	35	3/8" NPT							
	MR - 17V	17		230	35	3/8" NPT							
	ML - 5	5	700	200	45	50	3/8" NPT	G 1/2"	186	31	6,5		
	ML - 7	7		300	45	50	3/8" NPT	G 1/2"	286	31	6,5		
	ML - 9	9		400	45	50	3/8" NPT	G 1/2"	386	31	6,5		
	ML - 11	11		500	45	50	3/8" NPT	G 1/2"	486	31	6,5		

	MODEL	NUMBER OF USES	MAX WORKING PRESSURE (bar)	DIMENSIONS (mm)
	VM5A/2	3	700	
	VM5A/4	5	700	

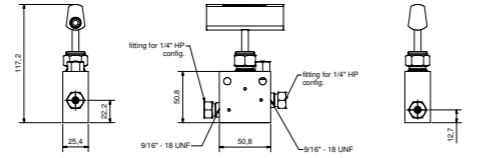
INTEGRATED MANIFOLD FOR DOUBLE ACTING	MODEL	NUMBER OF USES	MAX WORKING PRESSURE (bar)	MASS (KG)	DIMENSIONS (mm)
	MI-4DE-M	4	700	19	
	MI-8DE-M	8		19+19	

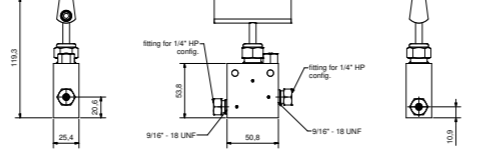
AUXILIARY COMPONENTS AND VALVES

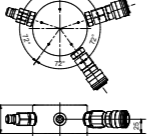
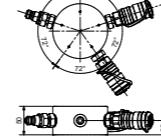
	MODEL	NUMBER OF USES	MAX WORKING PRESSURE (bar)	DIMENSIONS (mm)
	VM5A/1600	2	1600	
	VM5A/2000	2	2000	
	VM5A/4000	2	4000	

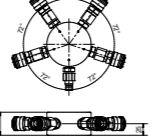
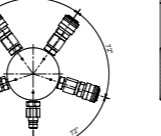
	MODEL	NUMBER OF USES	MAX WORKING PRESSURE (bar)	DIMENSIONS (mm)	
	MR3V/1500	3	1500	MR3V/1500	MR3V/2500
	MR3V/2500	3	2500		
	MR5V/1500	5	1500	MR5V/1500	MR5V/2500
	MR5V/2500	5	2500		

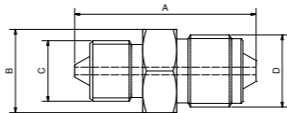
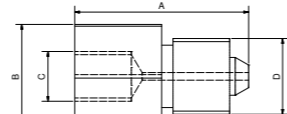
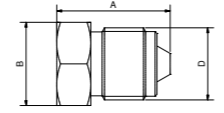
TYPE	MODEL	MAX WORKING PRESSURE (bar)	DIMENSIONS (mm)				
			A	B	C	D	
NIPPLE	0925613265	2000	45	CH 17	G"1/4 - 120°	G"1/4 - 120°	
NIPPLE	09299199501611	3000	48,5	CH 21	G"1/4 - 120°	3/4" - 16 UNF	
NIPPLE	0922225257	3000	48	CH 22	M16x1,5	3/4" - 16 UNF	
NIPPLE	0922225482	3000	42	CH 22	G"1/4 - 60°	3/4" - 16 UNF	
NIPPLE	0922225016	4000	40	CH 19	M16x1,5	9/16" - 18 UNF (1/4" HP)	
REDUCTION	0929112241	2500	45	CH 27	G"1/4" - 120° F	3/4"-16 UNF M	
PLUG	0925614601	2000	30	CH 17	-	G"1/4 - 120°	
	0922225585	3000	30	CH 22	-	3/4" - 16 UNF	
	0922221364	4000	26	CH 17	-	9/16" - 18 UNF (1/4" HP)	

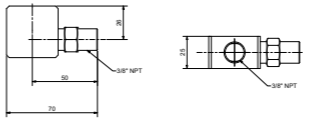
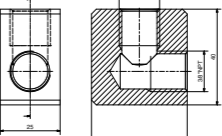
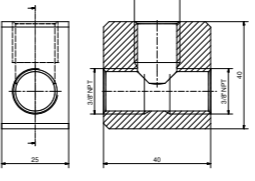
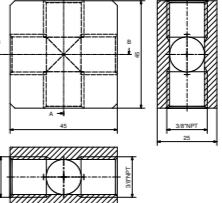
TYPE	MODEL AND DIMENSIONS	
	G-241	GF-242
ELBOW		
T-FITTING - CROSS FITTING	T-342	C-442
		

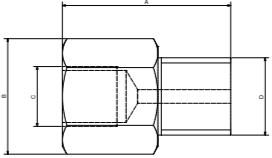
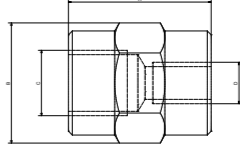
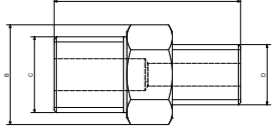
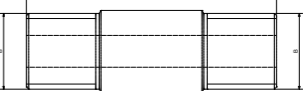
TYPE	MODEL	DIMENSIONS (mm)				
		A	B	C	D	
REDUCTION	R-313	40	CH 27	1/4" NPT	3/8" NPT	
	R-314	40	CH 27	3/8" NPT	1/4" NPT	
	R-316	45	CH 32	G 1/2"	1/4" NPT	
	R-352	45	CH 32	G 1/2"	3/8" NPT	
HEX COUPLING	ME-349	37	CH 27	3/8" NPT	3/8" NPT	
	ME-357	37	CH 27	1/4" NPT	3/8" NPT	
NIPPLE	N-341	39	CH 17	1/4" NPT	1/4" NPT	
	N-343	41	CH 19	1/4" NPT	3/8" NPT	
	N-344	41	CH 19	3/8" NPT	3/8" NPT	
LONG NIPPLE	NL-345	55	3/8" NPT	-	-	
	NL-346	80	3/8" NPT	-	-	
	NL-347	150	3/8" NPT	-	-	



MODEL	LITRES
OIL - 1	1
OIL - 5	5
OIL - 10	10
BIO-OIL-1	1
BIO-OIL-5	5
BIO-OIL-10	10

MINERAL HIDRAULIC OIL ISO VG 32
Available different oil for custom applications.

BIO OIL - Eco-friendly oil
Eco-friendly oil. High-performance, fully synthetic, biodegradable, non-toxic hydraulic fluid, saturated esters made.







F.P.T. / BOLT TIGHTENING EQUIPMENT

VERSATILE SOLUTIONS



INDEX

TORQUE AND TENSIONING

	Series		PAGE
Hydraulic bolt tensioners	TTS CTP		124
Pumps and HPU for hydraulics tensioners and nuts	FPT PDS PP		130
Hydraulic torque wrenches and pumps	FPT-MPU FPT HTW		136
Hydraulic nuts	GH		146





CUSTOM HYDRAULIC BOLT TENSIONERS

F.P.T. can provide custom design bolt tightening solutions from 700 to 2.500 bar. The relevant markets more and more require hydraulic bolt tensioners built to the customer's to specifics operate within the required geometry. F.P.T. supports customers from studying the layout to the 3D model and the production of the requested tensioners.

F.P.T. doesn't just produce tensioners, but also supports the customer in developing the hydraulic circuit, providing the hydraulic pumps and all the components needed to get the system running.

- Tensioning accuracy. The tensioner, by applying a direct force on the stud, allows very high accurate tightening, directly proportional to the pressure applied to the tensioner itself.
- Easy calculation of the force to be applied to the stud. The calculation of force is simple and F.P.T. provides all the force / pressure conversion data.
- Speed and repeatability in tightening operations. Easy to set up and fast in carrying out the tensioning operation, guaranteeing very high repetitiveness as well.
- Less stress. By this tightening method the studs are less stressed because there are no torsional forces, just axial ones.

Series **TTS** | Standard hydraulic bolt tensioners



PRODUCT
PAGE

High forces – reduced dimensions: anti over-stroke device.

CUSTOM TENSIONERS ON REQUEST



• TTS Series tensioners are designed to suit most flanges type: ANSI B16.5 - ANSI B16.47 - B.S.3293 - AWWA - MSS-SP44 - API-6A - API-17D - UNI EN 1092-1.

• High forces and reduced dimensions. TTS Series tensioners represent the optimal combination between the developed strength and their size.

• Extremely compact dimensions and low weight. In TTS series the spaces for the installation are reduced to a minimum level and operations are facilitated by reduced weights.

• Maximum flexibility. With only 6 hydraulic cells the operator can cover an extended range of Imperial or Metric thread sizes from 3/4" to 4" (M20 – M100).

• 15 mm stroke cover most of the tensioning application. If longer strokes are required the tensioning operation can be carried on by steps.

• All components are manufactured with hardened high tensile strength steel.

• Special treatment to guarantee: high resistance to corrosion - high resistance to wear – extremely low friction to help during screw operations.

• Safety is a must. All size have over stroke indicators.

• All model are equipped with 2 quick couplers, male and female, for serial hydraulic connection.

• Special high quality seals for leak free operations and easy maintenance.

TTS

3/4" to 4" (M20-M100)
236 kN - 2.820 kN
Stroke 10 - 15 mm
1.500 bar

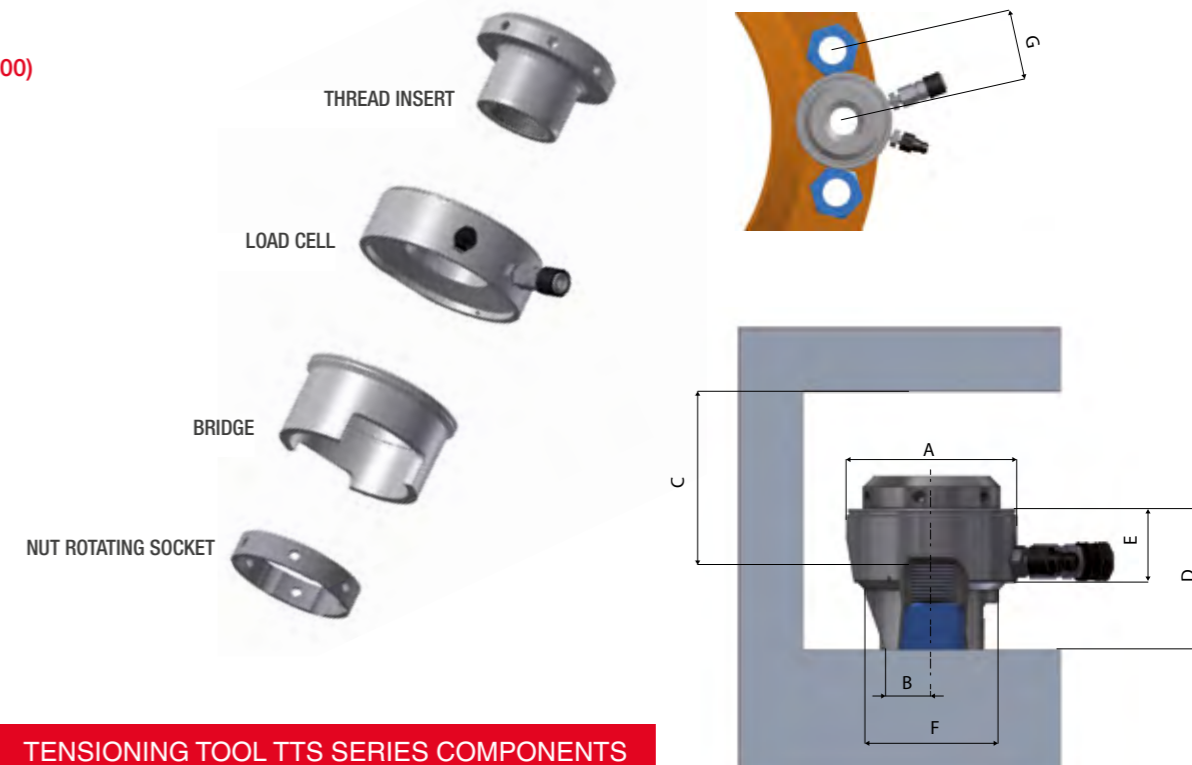

TENSIONING TOOL TTS SERIES COMPONENTS

HYDRAULIC CELL	IMPERIAL ADAPTER KITS		METRIC ADAPTER KITS		FORCE		HYDRAULIC AREA		STROKE	WEIGHT	DIMENSIONS (mm)					
	Thread size	Kit code	Thread size	Kit code	kN	Ton	in ²	mm ²			A	B	C	D	E	F
TTS1	3/4"-10 UNC	1.KI030410UNC	M20x2,5	1.KM.020025	236,5	24,1	2,44	1576,46	10	2	73	16	75	52	44,50	
	7/8"-9 UNC	1.KI070809UNC	M22x2,5	1.KM.022025								22	79	58	50,50	
	1"-8 UN	1.KI100008UN	M24x3	1.KM.024030								23	81	62	55	
	1.1/8"-8 UN	1.KI110808UN	M27x3	1.KM.027030								24	81	68	61	
TTS2	1.1/8"-8 UN	2.KI110808UN	M27x3	2.KM.027030	459,5	46,8	4,75	3063,05	15	4,6	101	25	104	75	64,50	
	-	-	M30x3,5	2.KM.030035								25	104	75	64,50	
	1.1/4"-8 UN	2.KI110408UN	M33x3,5	2.KM.033035								28	108	80	69,50	
	1.3/8"-8 UN	2.KI130808UN	M36x4	2.KM.036040								30	111	84	74,50	
TTS3	1.1/2"-8 UN	2.KI110208UN	M39x4	2.KM.039040	831,3	84,7	8,59	5541,77	15	7,7	133	34	106	95	82,50	
	1.5/8"-8 UN	3.KI150808UN	M42x4,5	3.KM.042045								36	109	104	90	
	1.3/4"-8 UN	3.KI130408UN	M45x4,5	3.KM.045045								40	112	108	94,50	
	1.7/8"-8 UN	3.KI170808UN	M48x5	3.KM.048050								42	117	112	99,50	
TTS4	2"-8 UN	3.KI200008UN	M52x5	3.KM.052050	1345,5	137,2	13,90	8970,03	15	13,7	163	43	125	122	104,50	
	1.7/8"-8 UN	4.KI170808UN	M48x5	4.KM.048050								45	128	123	108	
	2"-8 UN	4.KI200008UN	M52x5	4.KM.052050								54	133	63	132	117,50
	2.1/4"-8 UN	4.KI210408UN	M56x5,5	4.KM.056055								53	137	140	120,50	
TTS5	2.1/2"-8 UN	4.KI210208UN	M64x6	4.KM.064060	1927,3	196,5	19,91	12848,33	15	18,9	193	57	141	146	128	
	-	-	M60x5,5	4.KM.060055								59	134	148	131	
	2.1/2"-8 UN	5.KI210208UN	M64x6	5.KM.064060								59	137	63	154	135
	2.3/4"-8 UN	5.KI230408UN	M68x6	5.KM.068060								62	137	63	154	135
TTS6	3"-8 UN	6.KI300008UN	M76x6	6.KM.076060	2819,9	287,5	29,14	18799,29	15	34,3	232	75	160	170	153	
	-	-	M80x6	6.KM.080060								77	165	177	155	
	3.1/4"-8 UN	6.KI310408UN	M85x6	6.KM.085060								77	170	182	164,50	
	3.1/2"-8 UN	6.KI310208UN	M90x6	6.KM.090060								82	175	73	191	174,50
	3.3/4"-8 UN	6.KI330408UN	M95x6	6.KM.095060								86	180	206	187,50	
	4"-8 UN	6.KI400008UN	M100x6	6.KM.100060								95	185	216	198	



PRODUCT
PAGE

For big sizes

CUSTOM TENSIONERS ON REQUEST



The hydraulic bolt tensioners with threaded insert are characterised by the threaded interchangeable insert which makes it possible to work on studs with various threads, using just one hydraulic cell.

This configuration is extremely versatile whenever stud with different threads and similar clearance must be tensioned, all you need is a set of inserts different sockets and in some cases reaction bridges.

F.P.T. is specialized in the study and production of custom hydraulic bolt tensioners from 700 to 2,500 bar.



PRODUCT
PAGE

To be compact

CUSTOM TENSIONERS ON REQUEST



The compact hydraulic bolt tensioners have the thread integrated in the piston.

This characteristic reduces the overall size at a minimum level, allowing you to have a tensioner with extremely small dimensions and to be able to operate where other tensioners could not be installed.

F.P.T. produces this model of tensioner, with threaded piston, in all those cases in which it is not possible to meet the requirements of dimensions without recurring to multistage tensioner.

Spring return version or pneumatic return can be realised to speed up the return operations of the piston.

Series **CTP-M** | Multi-stage hydraulic bolt tensioners



PRODUCT
PAGE

High forces, low clearance

CUSTOM TENSIONERS ON REQUEST



The CTP-M series is characterised by a central puller which two loading cells operate on, this construction makes it possible to double the load capacity whilst keeping the external cell dimension the same. The results obtained are very tight clearances with the load supplied remaining equal.

The multistage tensioners F.P.T. are suitable for all applications where there are reduced radial dimensions available.

This type of tensioner is available also in the version with gear rotation nut mechanism to accelerate tensioning operations. Also there is the possibility of shaping the bridge to best match the available space among nuts.

F.P.T. realizes multistage hydraulic bolt tensioners according to customer specifications by carrying out a preliminary study on the existing dimensions and thus offering the most suitable solution.

Hydraulic bolt tensioners for the wind turbine sector | Series **CTP-W**



PRODUCT
PAGE

For wind and renewables

CUSTOM TENSIONERS ON REQUEST



F.P.T. - Fluid Power Technology produces a wide range of wind tensioners, CTP-W series, specifically designed for the wind power sector, for bolted joints of a wind turbine. Extremely compact, they are capable of developing very high forces, designed and engineered for turbine installation and subsequent maintenance.

They have a compact structure, equipped with a piston, spring return and / bush screwing / unscrewing nut device on the stud with ratchet wrench. Equipped with adjustable joint for 360° rotation to place the flexible hoses in the best possible position in order to allow the free access to tensioning tools. Automatic piston return system for maximum speed in operations, nut unscrewing/screwing system and the assisted key positioning equipped.

The wind tensioners are especially designed to tighten swivel ring, bolts, hub and blades of wind towers. They are light, easy to use, easy to handle and carefully designed for greater reliability and durability.

All components are made of high resistance steel and have a special treatment to guarantee a high resistance against corrosion and a high resistance to wear during screwing operations and equipped with Long Life Time Puller.

Series
PDSA

Hand pumps for bolt tensioners and hydraulic nuts 1.600 - 3.000 bar, aluminium made



PRODUCT
PAGE

**For bolt tensioners
and hydraulic nuts**

CUSTOM PUMPS ON REQUEST



- Very high pressure hand pumps produced in light-weight aluminum alloy of aeronautics grade to reduce weight to a minimum level. The most flexible solution for driving hydraulic bolt tensioners and nuts.
- Two-stage versions at 1,600 bar and 3,000 bar with 40 cc displacement at the first stage for a rapid approach and 1 cc at the second stage.
- Pressure relief valve integrated in the pump body for maximum operator safety.
- Very high pressure, high performance, reduced effort on the handle and ergonomics.
- Integrated pressure gauge connection for direct mounting of the measuring instrument.
- Oil filler cap with integrated breather. Tough pins with trough-holes for attachment to machinery or structures.
- Surface treatments to guarantee total reliability in the most difficult environments and maximum duration.

PDSA

1.600 - 3.000 bar
40/1 cm³ oil displacement
Double stage
1,8 l oiltank capacity

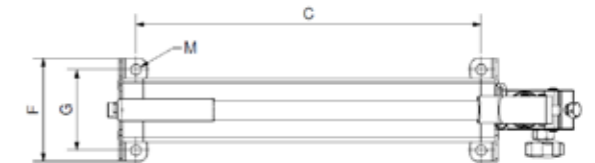
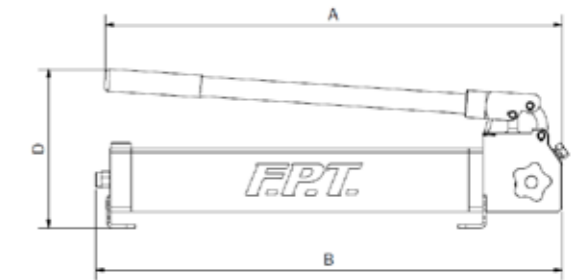
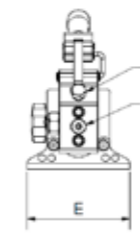

PDSA 1600-3000

TYPE OF PUMP	MODEL	PRESSURE	OIL	OIL TANK	USABLE OIL	DIMENSIONS (mm)										WEIGHT
		1°/2° STAGE	DISPLACEMENT	CAPACITY		litres	A	B	C	D	E	F	G	H	M	
DOUBLE STAGE	PDSA-1600	25/1600	40/1	1,8	1,6	577	588,5	436	200	130	130	102	1/4" GAS	13	1/2" GAS	7,8
DOUBLE STAGE	PDSA-3000	16/3000	40/0,5	1,8	1,6	577	588,5	436	200	130	130	102	3/4"-16 UNF	13	9/16"-18 UNF	7,8

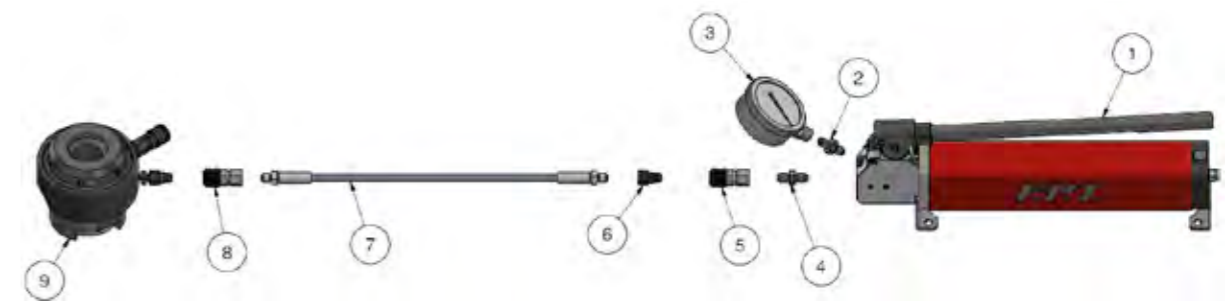

Configuration No.1 – Quick coupler on pump
Configuration No.2 – Flex hose directly assembled on the pump

	1500 Bar - Config.1	1500 Bar - Config.2	1600 Bar - Config.1	1600 Bar - Config.2	2500 Bar - Config.1	2500 Bar - Config.2	3000 Bar - Config.1	3000 Bar - Config.2
ITEM	CODE	CODE	CODE	CODE	CODE	CODE	CODE	CODE
1	01PDSA1600	01PDSA1600	01PDSA1600	01PDSA1600	01PDSA3000	01PDSA3000	01PDSA3000	01PDSA3000
2	-	-	-	-	0922225016	0922225016	0922225016	0922225016
3	01MD200G	01MD200G	01MD200G	01MD200G	01MD300G	01MD300G	01MD300G	01MD300G
4	0925613265	-	0925613265	-	09299199501611	0929112241	0922225257	0922225482
5	07GR15F	-	07GR20F	-	07GR25F	-	07GR30F	-
6	07GR15M	-	07GR20M	-	07GR25M	-	07GR30M	-
7	01TFR#/1800	01TFR#/1800	01TFR#/1800	01TFR#/1800	01TFR#/2500	01TFR#/2500	01TFR#/3000M16D	01TFR#/3000M16G
8	07GR15F	07GR15F	07GR20F	07GR20F	07GR25F	07GR25F	07GR30F	07GR30F
9	Tool	Tool	Tool	Tool	Tool	Tool	Tool	Tool

insert length of the hose expressed in meters

Series **FPT C7** | Electric pump 1500 - 2000
and 3000 bar



PRODUCT
PAGE

**For bolt tensioners and
hydraulic nuts**

CUSTOM PUMPS ON REQUEST



- Single-phase electric power pack suitable to operate hydraulic bolt tensioners and nuts.
- On request different engines, capacities and pressure are available.
- The electric pump is available in three versions: 1.500 - 2.000 and 3.000 bar.
- The pressure regulating valve allows easy output pressure setting.
- Control pendant for easy operation control.
- Data Logger option available as an option, for the download of tightening values.

FPT C7

1.500 to 3.000 bar
40/1 cm³ oil displacement
Double stage
7 l oiltank capacity

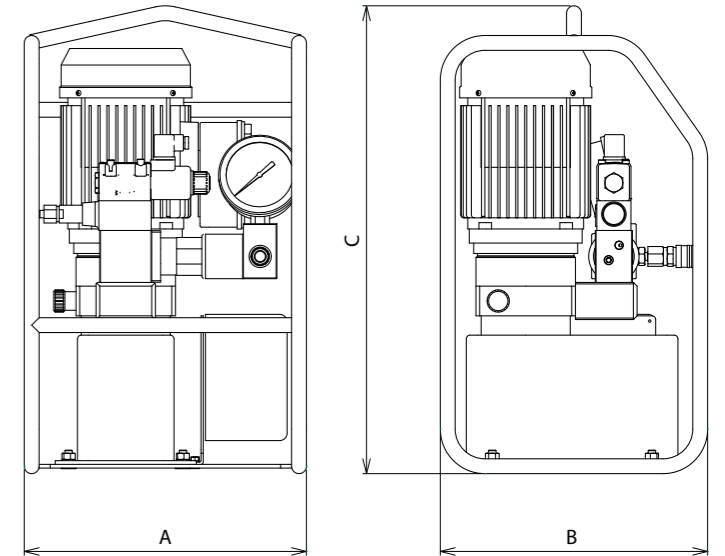

FPT C7

MODEL	PRESSURE	OIL FLOW	MOTOR	KW RPM	VALVE	OILTANK CAPACITY	DIMENSIONS			WEIGHT	ACCESSORIES
	bar	l/min			kW/rpm		litres	A	B		
FPT-1500-EV4/3-C7	120/1500	4,5/0,35	SINGLE PHASE, 4 POLES	1,1/1400	SOLENOID VALVE	7	380	360	630	38	PENDANT
FPT-1500-EV4/3-D-C7	120/1500	4,5/0,35	SINGLE PHASE, 4 POLES	1,1/1400	SOLENOID VALVE	7	380	360	630	39	PENDANT WITH DIGITAL DISPLAY
FPT-2000-EV4/3-C7	120/2000	3,7/0,12	SINGLE PHASE, 4 POLES	1,1/1400	SOLENOID VALVE	7	380	360	630	38	PENDANT
FPT-3000-EV4/3-C7	185/3000	3,2/0,15	SINGLE PHASE, 4 POLES	1,1/1400	SOLENOID VALVE	7	380	360	630	38	PENDANT

On request it is possible to have control pendant with digital pressure indicator even for pressures > 1500 bar



Series
PP

**Pneumohydraulic pumps
for bolt tensioners and
hydraulic nuts**



PRODUCT
PAGE

**For bolt tensioners and
hydraulic nuts**

CUSTOM PUMPS ON REQUEST



- PP series power packs are the ideal solution for all very high pressure applications when compressed air line connection is needed.
- Hydraulic pumps for stud tensioning, burst tests, laboratory tests, scaling or keying of bearings, actuation of hydraulic bolt tensioners or hydraulic nuts and wherever high pressure is required.
- Standard versions with pressure 1500 bar - 2500 bar - 3000 bar and 4000 bar.
- Equipped with pressure relief valve for maximum operative safety.
- Handwheel pressure regulator valve.
- Pressure gauge, female quick coupler and standard assembly pneumatic regulator filter on all models.
- Models available with remote control pendant.
- Possibility to design and produce custom hydraulic power units on request, with dedicated performance and features.

PP

Single stage
5 to 10 l oiltank capacity
1500 to 3000 bar

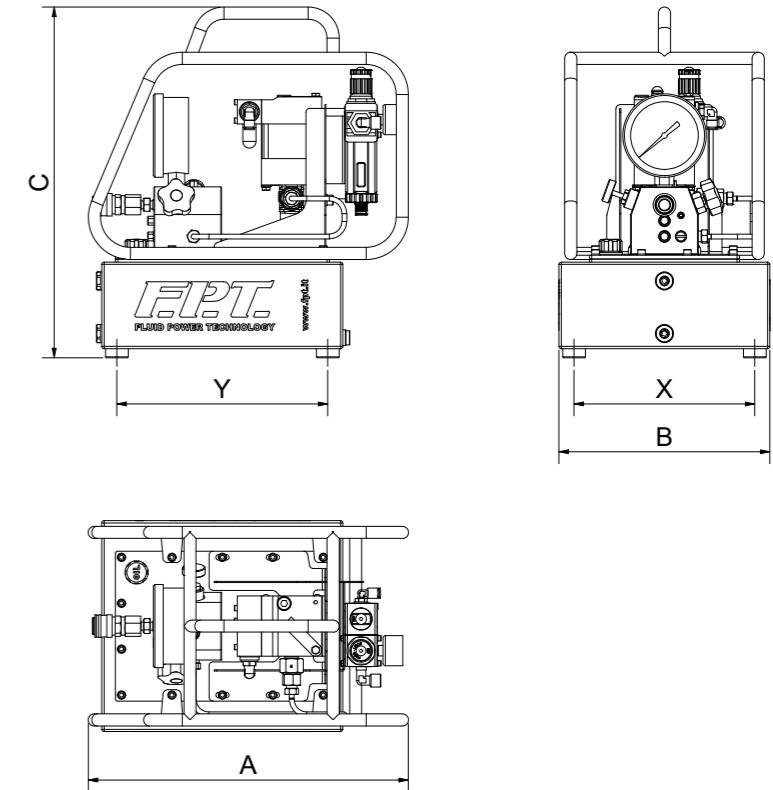

PP

MODEL	HYDRAULIC PRESSURE	MIN. AIR INLET PRESSURE	AVG. AIR CONSUMPTION	MULTIPLICATION RATIO	NO LOAD OIL DISPLACEMENT	OIL DISPLACEMENT AT MAX OIL PRESSURE	OILTANK CAPACITY	AIR PRESSURE RANGE	LENGTH	WIDTH	HEIGHT	FIXING HOLES	SIDE INTERAXIS	FRONT INTERAXIS	WEIGHT (WITH OIL)
	bar	bar	l/min	-	l/min	l/min	litres	bar	A	B	C	-	X	Y	kg
PP1500C05	1500	7	500	1:220	0,28	0,01 @ 7 bar	5	1 - 10 bar	425	265	466	nr.4 M8x12	165	250	19,5
PP1500C10	1500	7	500	1:220	0,28	0,01 @ 7 bar	10		425	280	466	nr.4 M8x12	240	280	25,5
PP1500C05/CDP	1500	7	500	1:220	0,28	0,01 @ 7 bar	5		425	265	466	nr.4 M8x12	165	250	21,0
PP1500C10/CDP	1500	7	500	1:220	0,28	0,01 @ 7 bar	10		425	280	466	nr.4 M8x12	240	280	27,0
PP2500C05	2500	6	600	1:440	0,21	0,03 @ 6 bar	5		425	265	466	nr.4 M8x12	165	250	20,5
PP2500C10	2500	6	600	1:440	0,21	0,03 @ 6 bar	10		425	280	466	nr.4 M8x12	240	280	26,5
PP2500C05/CDP	2500	6	600	1:440	0,21	0,03 @ 6 bar	5		425	265	466	nr.4 M8x12	165	250	22,0
PP2500C10/CDP	2500	6	600	1:440	0,21	0,03 @ 6 bar	10		425	280	466	nr.4 M8x12	240	280	27,5
PP3000C05	3000	8	700	1:440	0,21	0,06 @ 8 bar	5		425	265	466	nr.4 M8x12	165	250	20,5
PP3000C10	3000	8	700	1:440	0,21	0,06 @ 8 bar	10		425	280	466	nr.4 M8x12	240	280	26,5
PP3000C05/CDP	3000	8	700	1:440	0,21	0,06 @ 8 bar	5		425	265	466	nr.4 M8x12	165	250	22,0
PP3000C10/CDP	3000	8	700	1:440	0,21	0,06 @ 8 bar	10		425	280	466	nr.4 M8x12	240	280	27,5

Series **FPT-MPU-HTW** | Portable mini pumps for hydraulic torque wrenches



PRODUCT
PAGE

To be carried everywhere

CUSTOM PUMPS ON REQUEST



- Portable mini pump, extremely light and compact, suitable for using all small and medium sized torque wrenches.
- **Only 12 kg weight to operate in any environment.**
- Maximum working pressure pressure 700 bar.
- Single-phase electric motor 230V-50Hz, power 0.55 kW.
- Radial piston pump, double stage, suitable for heavy-duty applications.
- 2.1 liter resin tank.
- Metal cage with ergonomic handle.
- Pressure gauge and valve handwheel pressure regulator as standard.
- GR-1 quick coupling as standard on the outports.

FPT-MPU-HTW

700 bar
Double stage
1/0,5 l/min oil flow
2,1 l oiltank capacity

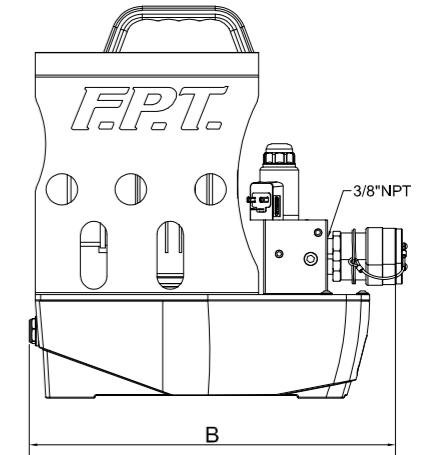
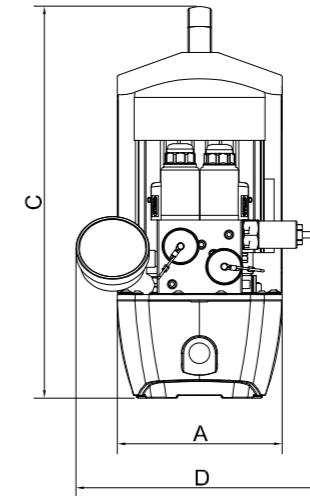

FPT-MPU-HTW

CODE	MODEL	PRESSURE	OIL FLOW	MOTOR	TENSION/ FREQUENCY	POWER/ RPM	TANK CAPACITY	DIMENSIONS mm				WEI- GHT
		1°/2° STAGE	l/min			kW/rpm	litres	A	B	C	D	kg
31FPTMPUHTW	FPT-MPU-HTW	75/700	1/0,5	MONO PHASE ELECTRIC	230V-50Hz	0,55/2800	2,1	155	344	372	238	12

F.P.T. / SQUARE DRIVE TORQUE WRENCHES, LOW CLEARANCE TORQUE WRENCHES, HYDRAULIC PUMPS AND ACCESSORIES



Contact F.P.T. to receive the complete catalog of hydraulic torque wrenches

F.P.T. offers a wide variety of products for controlled tightening to better meet the customer's specific needs and applications. Including hydraulic torque wrenches, compact and high-flow power packs, twin flex hoses, quick couplers and all the accessories required to complete the system.

Any tightening can be executed with F.P.T.'s torque wrenches. Handy and compact models, square drive and low clearance.

- Accuracy
- Reliability
- Low weight
- Excellent performance



Series
FPT-HTW-C

Compact pumps electric
and pneumatic for hydraulic
torque wrenches



PRODUCT
PAGE

To stay light
and compact

CUSTOM PUMPS ON REQUEST



- The FPT-HTW-C is a compact pump that provide the power for your torque wrenches.
- The FPT-HTW-C10 Series is available in both single port models for single tool operation and quad port models for running up to four tools simultaneously.
- The sight glasses enable operator to monitor reservoir oil levels and the transport cage for all around protection and easy handling.
- The hydraulic pump is available in electric or pneumatic version, with different 2-Stage delivery.
- For this model are available different accessories. For both version the heat exchanger, quick couplers and twin hoses, for FPT9-HTW-C10 the quad block and the auto cycle - for automatic operation. It is also possible totally customize the pump up to the customers' needs.

FPT-HTW-C

700 bar
Two speed
3,5/0,45 - 7,9/0,9 l/m
5 to 10 l capacity

FPT-HTW-C

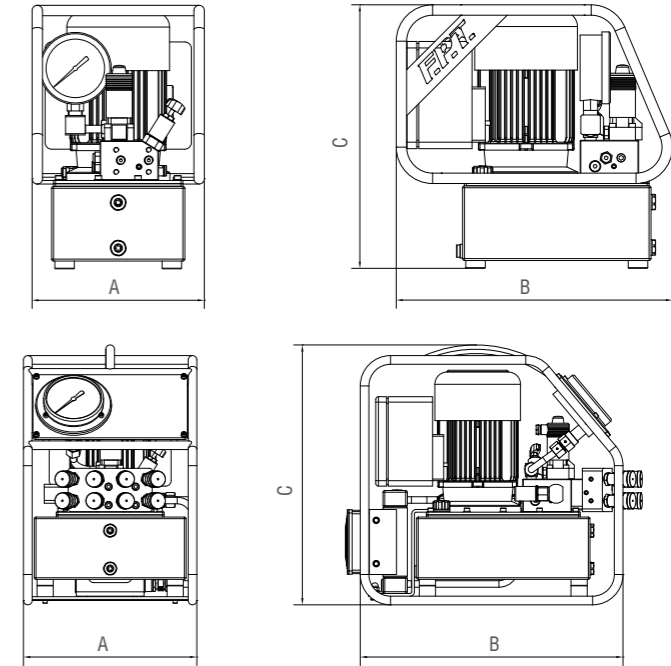

CODE	MODEL	PRESSURE	OIL FLOW	MOTOR	TENSION/ FREQUENCY	POWER/ RPM	TANK CAPACITY	DIMENSIONS (mm)			WEIGHT
		1°/ 2° STAGE	l/min					litres	A	B	
51001	FPT9-ME41-HTW-C05	80/700	3,5/0,45	MONO PHASE ELECTRIC	230V-50Hz	0,75/1370	5	265	425	405	29
51002	FPT9-ME41-HTW-C05-SC	80/700	3,5/0,45	MONO PHASE ELECTRIC	230V-50Hz	0,75/1370	5	265	425	405	34
51088	FPT9-ME21-HTW-C05-SC	80/700	7,5/0,9	MONO PHASE ELECTRIC	230V-50Hz	1,5/2850	5	265	425	405	34
51003	FPT9-MA-HTW-C05	80/700	5,6/0,65	PNEUMATIC	-	1,3/3000	5	265	425	405	27
51004	FPT9-ME21-HTW-C10	80/700	7,5/0,9	MONO PHASE ELECTRIC	230V-50Hz	1,5/2850	10	320	485	480	36
51005	FPT9-ME21-HTW-C10-SC	80/700	7,5/0,9	MONO PHASE ELECTRIC	230V-50Hz	1,5/2850	10	320	485	480	40
51006	FPT9-ME21-HTW-C10-Q	80/700	7,5/0,9	MONO PHASE ELECTRIC	230V-50Hz	1,5/2850	10	320	485	480	38
51008	FPT9-ME21-HTW-C10-SC-Q	80/700	7,5/0,9	MONO PHASE ELECTRIC	230V-50Hz	1,5/2850	10	320	485	480	43
51009	FPT9-ME21-HTW-C10-SC-Q-AC	80/700	7,5/0,9	MONO PHASE ELECTRIC	230V-50Hz	1,5/2850	10	320	485	480	44
51011	FPT9-ME21-HTW-C10-AC-SC	80/700	7,5/0,9	MONO PHASE ELECTRIC	230V-50Hz	1,5/2850	10	320	485	480	42
51012	FPT9-MA-HTW-C10	80/700	7,9/0,9	PNEUMATIC	-	1,3/3000	10	320	485	480	34
51013	FPT9-MA-HTW-C10-Q	80/700	7,9/0,9	PNEUMATIC	-	1,3/3000	10	320	485	480	36

OPTIONS

SC	HEAT EXCHANGER
Q	QUAD BLOCK
AC	AUTO CYCLING



Series **FPT-HTW-HF** | High flow pumps
for torque wrenches



PRODUCT
PAGE

When is needed a
very high flow

CUSTOM PUMPS ON REQUEST



- The pump FPT-HTW-HF is a high flow version typically used for intensive job with multiple tools.
- The pump is available on three-phase version with 15 l/min at 100 bar and 3 l/min at 700 bar.
- The pump is equipped with protection cage and wheels for easy handling.
- Standard for this model are: heater exchanger, quad block manifold and oil return filter.
- There are also available different accessories: automatic cycle, quick couplers and twin hoses.
- The FPT-HTW-HF can also be equipped with different pumps and flow related to the torque specifications.
- Automatic cycle available for heavy duty operations.

FPT-HTW-HF

700 bar
15/3 l/min
Two speed
40 l capacity

FPT-HTW-HF

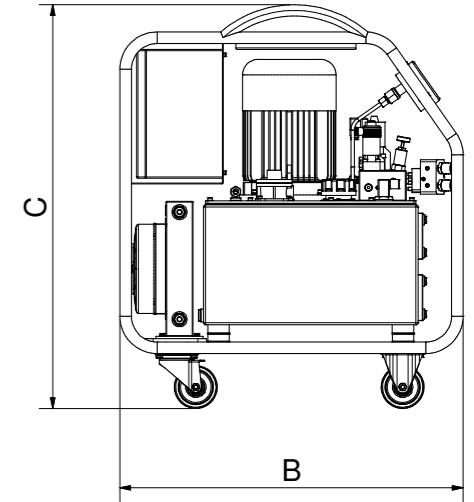
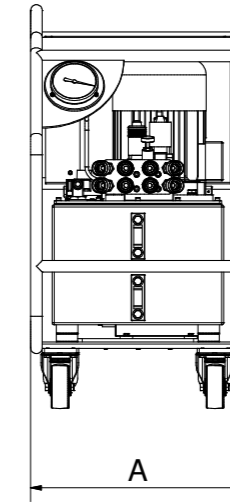

CODE	MODEL	PRESSURE	OIL FLOW	MOTOR	TENSION/ FREQUENCY	POWER/RPM	TANK CAPACITY	DIMENSIONS (mm)			WEIGHT
		1°/ 2° STAGE						litres	A	B	
51086	FPT15-ME4-HTW-HF40	100/700 bar	15/3 l/min	THREE PHASE	400V-50Hz	4/1450 kW/rpm	40	500	800	940	100
51087	FPT15-ME4-HTW-HF40-AC	100/700	12/3	THREE PHASE	400V-50Hz	4/1450	40	500	800	940	100



**ACCESSORIES
AND CUSTOM
MADE**

Accessories and custom made pumps for hydraulic torque wrenches



Twin hoses for torque wrenches

FPT is specialized in the study and production of hydraulic pumps for custom hydraulic torque wrenches.

High flow versions, compact and lightweight, for simultaneous use of multiple tools, atex certified, with heat exchangers and many other customizations based on the characteristics of the customer's application.

Available different types of hoses length and quick couplers.

MODEL	HOSE AND COUPLERS ASSEMBLY		LENGTH m	PRESSURE BAR
	PUMP END	WRENCH END		
TTFG-5-HTW	N°2 NIPPLES 1/4"	GR1M + GR1F	5	700
TTFG-6-HTW	N°2 NIPPLES 1/4"	GR1M + GR1F	6	700
TTFG-10-HTW	N°2 NIPPLES 1/4"	GR1M + GR1F	10	700
TTFG-5-HTW-C	N°2 NIPPLES 1/4"	GR5M + GR5F	5	700
TTFG-6-HTW-C	N°2 NIPPLES 1/4"	GR5M + GR5F	6	700
TTFG-10-HTW-C	N°2 NIPPLES 1/4"	GR5M + GR5F	10	700
TTFGG-5-HTW	GR1M + GR1F	GR1M + GR1F	5	700
TTFGG-6-HTW	GR1M + GR1F	GR1M + GR1F	6	700
TTFGG-10-HTW	GR1M + GR1F	GR1M + GR1F	10	700
TTFGG-5-HTW-C	GR5M + GR5F	GR5M + GR5F	5	700
TTFGG-6-HTW-C	GR5M + GR5F	GR5M + GR5F	6	700
TTFGG-10-HTW-C	GR5M + GR5F	GR5M + GR5F	10	700





PRODUCT
PAGE

Hydraulic nuts

CUSTOM PUMPS ON REQUEST



- Hydraulic nuts are used in all those applications where it is not possible to use a mechanical nut because of continuous maintenance operations, heat, vibrations or other factors.
- Replace existing hex nuts to provide an accurate and uniform load at every bolted connection.
- Allow to tighten large diameter bolts, with high and precise preloads easily.
- They can have upper or lower clamping collar and they are extremely compact, it is also possible to connect any number of hydraulic nuts for simultaneous operation, ensuring a uniform tensioning.
- The hydraulic nuts are used for installation and removal of components such as couplings, gears and ship propellers, rudder blades, rudder blade shaft coupling or large pieces on conical seats and for bearings assembling and disassembling.
- The hydraulic nuts can have various threads and dimensions, they are operated by a handpump or high pressure hydraulic pump. Customized solutions produced on request.
- They find application in the naval, iron and steel, mechanical sector.







F.P.T. / TOOLS AND SYSTEMS

PRODUCTION OF CUSTOM HYDRAULIC EQUIPMENT



INDEX

TOOLS AND SYSTEMS

	Series		PAGE
Nut splitters	TB		150
Hot Bolt & Industrial clamp	HBRC		152
Tightening tool for plate heat exchangers	HEAS		154
Hydraulic presses	PR		155



PRODUCT PAGE

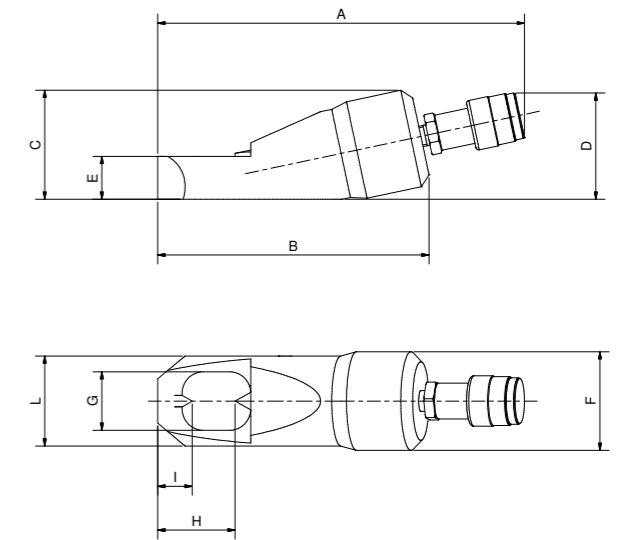

TB

To remove your nuts

CUSTOM TOOLS ON REQUEST



- Used when nuts are difficult to remove due to rust or wear.
- Equipped with fixed and mobile blades to cut the nut in a single operation: the blades can be sharpened or replaced.
- Used in the petrochemical, railway and nautical sectors.

SAFETY INSTRUCTIONS

- Can be used on hexagonal nuts with hardness under 44 HRC
- During the cutting phase, position the blade to the centre of the surface to cut
- Avoid touching the washer if present

SCREW DIAMETER	HEX NUT DIAMETER	MODEL	FORCE in ton	DIMENSIONS (mm)										WEIGHT kg	SPARE BLADE MODEL	
				A	B	C	D	E	F	G	H	I	L		FIXED BLADE	MOBILE BLADE
M8 - M12	13 - 19	TB 13/19	5,5	203	133	48	58	19	43	26	41	21	40	1,2	CF-13/19	CM-13/19
M12 - M16	19 - 24	TB 19/24	11	233	163	65	68	25	58	34	47	22	55	2,3	CF-19/24	CM-19/24
M16 - M22	24 - 32	TB 24/32	16,5	260	190	75	74	30	69	41	57	24	63	3,2	CF-24/32	CM-24/32
M22 - M27	32 - 41	TB 32/41	21,8	297	230	90	80	35	84	55	77	35	78	5,1	CF-32/41	CM-32/41
M27 - M33	41 - 50	TB 41/50	35	347	280	112	93	42	103	68	89	38	98	10,4	CF-41/50	CM-41/50
M33 - M39	50 - 60	TB 50/60	49,5	395	330	136	105	52	124	82	103	42	118	17,5	CF-50/60	CM-50/60
M39 - M48	60-75	TB 60/75	90	454	400	182	132	75	168	110	113	28	154	38,5	-	CM-60/75





PRODUCT
PAGE

Replacement of damaged nuts – Industrial Clamping

CUSTOM TOOLS ON REQUEST



- FPT is a producer of Hot Bolt and Industrial Clamping System with applications throughout the industrial sectors, oil & gas as well.

- The system has been designed to remove rusted nuts on pipelines where it is essential to replace the corroded or damaged nuts without interrupting production.

- The standard system consists of 4 FPTs Hot Bolt of 34 kN with a 10 mm stroke and a maximum working pressure of 700 bar, an FPT hand pump model PMSA2, manifold, flex hoses, couplings and accessories. Every Hot Bolt is superficially treated to obtain an excellent resistance against corrosion. Product code: KIT-4HBRC-35

- The tools can be operated through multiple outputs: electric power unit, pneumo-hydraulic pumps and handpumps and the system can be personalized to meet customer's requirements.



Series **HEAS** | Tightening tool for plate heat exchangers



Assembly and disassembly system for plate heat exchangers



PRODUCT PAGE

- Tightening tool for plate heat exchangers, FPT code: HEAS is our assembly and disassembly system to perform opening and closing procedure on the exchangers.
- Precise, compact and light weight system for assembly and disassembly plate heat exchangers
- The best solution for customers with a variety of heat exchanger model sizes
- Aluminium hollow cylinders, open bridge and electric hydraulic pump to control 4 cylinders
- Full set of split nut, hex adapter and bushes

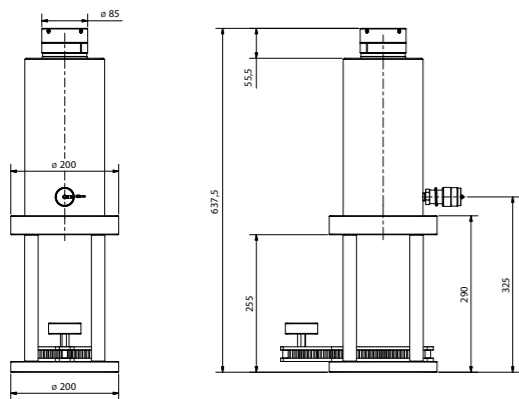

Spare parts list			
Item	Qty	Part Number	Description
A	1	0900119919	Wrench
A,1	1	0925419910	Hex adapter ex 75
A,2	1	0925419911	Hex adapter ex 70
A,3	1	0925419912	Hex adapter ex 65
A,4	1	0925419913	Hex adapter ex 60
A,5	1	0925419914	Hex adapter ex 55
A,6	1	0925419909	Hex adapter ex 80
B	1	0900127052	Retaining ring
B,1	1	0925427053	M36 split-nut
B,2	1	0925427054	M39 split-nut
B,3	1	0925427055	M42 split-nut
B,4	1	0925427056	M45 split-nut
B,5	1	0925427057	M48 split-nut
B,6	1	0925427058	M52 split-nut
C	1	0900127044	Spacer assembly
C,1	1	0913827046	D.37 bushing for spacer
C,2	1	0913827047	D.40 bushing for spacer
C,3	1	0913827048	D.43 bushing for spacer
C,4	1	0913827049	D.46 bushing for spacer
C,5	1	0913827050	D.49 bushing for spacer
C,6	1	0913827051	D.53 bushing for spacer (not visible)
D	1	0900127039	Hydraulic cylinder

Hydraulic Presses | Series **PR**



PRODUCT PAGE

- Built according to customer needs and specific operative requirements.
- Equipped with safety guards and systems, fixed or mobile bench, push piston and positioning function on request.
- They can also be equipped with a hand pump or hydraulic pump with electric or air motor.
- Correctly sized structure to guarantee maximum strength and stability during operations.

Multipurpose

CUSTOM TOOLS ON REQUEST



F.P.T. / SAFETY INSTRUCTIONS

All F.P.T. products are designed and built in full compliance with the international regulations regarding occupational safety. The following are some general guidelines regarding the correct and improper use of F.P.T. products. Before using any F.P.T. equipment carefully read the user and maintenance manuals available to download at www.fpt.it. Before operating equipment, always wear the required protective clothing. F.P.T. cannot be held liable for damage or injuries caused by the improper use of products or lack of maintenance. For any clarification or technical information, please contact F.P.T. The capacity and stroke values supplied by the manufacturer are the recommended ceiling values to ensure safety. It is recommended not to exceed 80% of these values.

The measurements and technical data provided are correct and verified at the time of printing. In any case, F.P.T. reserves the right to make any changes whatsoever to the products in this catalogue without notification. Because the products are constantly being developed, any of the information in this catalogue may be changed without notification. Please contact the F.P.T. technical office for further information if the final measurements are important.

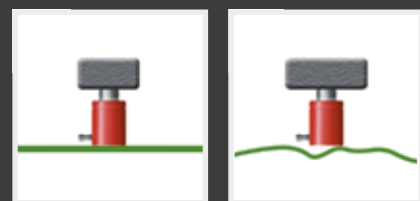

Cylinders must be stably positioned on smooth and even surfaces.

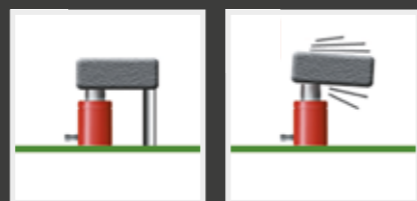

Loads must be mechanically secured, and never work underneath those loads.

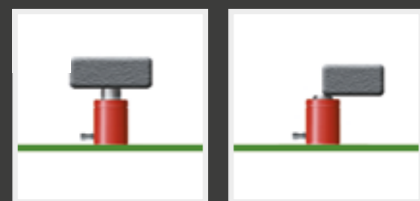

The anchor/support point of the load must be stable and centered along the cylinder's axis.

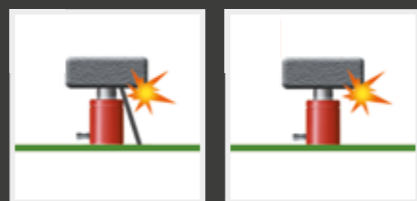

Do not expose equipment to heat sources or welding irradiation heating higher than 65°.



Maintenance operations must be carried out only when equipment is not under pressure. Do not disconnect joints under pressure. Never pressurize a semi coupler.

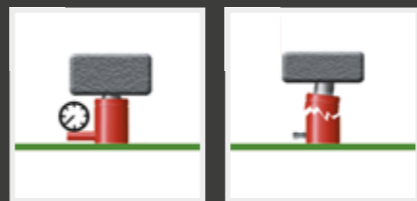

By means of a pressure gauge, check that the operating pressure does not exceed the rated pressure value indicated for that component.

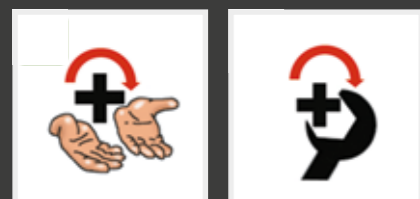

Do not use extensions on the pump handle or other tools on the manual controls of the valves.

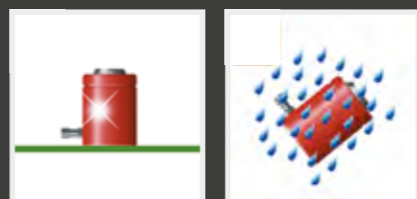

Keeping equipment clean and tidy will help save money on maintenance expenses.



Clean fittings before installing them in cylinders: foreign matter may enter the hydraulic system and damage its most delicate components.

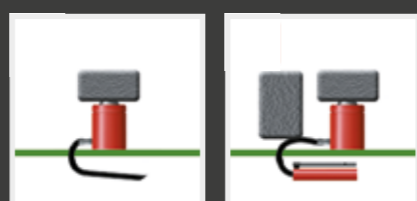

Do not overbend hoses and protect them against flattening.

F.P.T. / WARRANTY

F.P.T. products are warranted to be free of defects in workmanship under normal use for as long as they are owned by the original purchaser.

a product is defective, the product must be delivered to F.P.T. which, in its unquestionable judgement, if it deems the product to be defective, will be repaired or replaced under this warranty. The customer must pay for any and all expenses for transporting the product to/from F.P.T.

This warranty does not cover incorrect installation or use of the products, inadequate maintenance, alterations or repairs not authorized by F.P.T. or damage caused by transportation. All electric parts, motors, solenoid valves and in general all parts not supplied by F.P.T. are excluded from this warranty. Such items are warranted to the extent of the warranty provided by the manufacturers of such items.

F.P.T. will not be held liable for:

- any damage caused by defective or non-conforming products, negligence or any other damage
- any other obligations or liabilities arising out of breach of contract or of warranty. The warranty will not be applicable for non-payment (or even partial payment) of the goods supplied.

The warranty is limited only to new, original equipment products. If the customer believes



CE of conformity

F.P.T. supplies a declaration of conformity for each product and the CE mark for the products that comply with the directives of the European Community.





FLUID POWER TECHNOLOGY S.R.L.



Headquarters: Via Campo Sportivo, 54 - 16040 Ne (GE) Italy
Production plant: Via San Biagio, 18 - 16040 Ne (GE) Italy



+39 0185 337620



+39 0185 337525



info@fpt-worldwide.com

www.fpt-worldwide.com